

# Ürün Katalođu

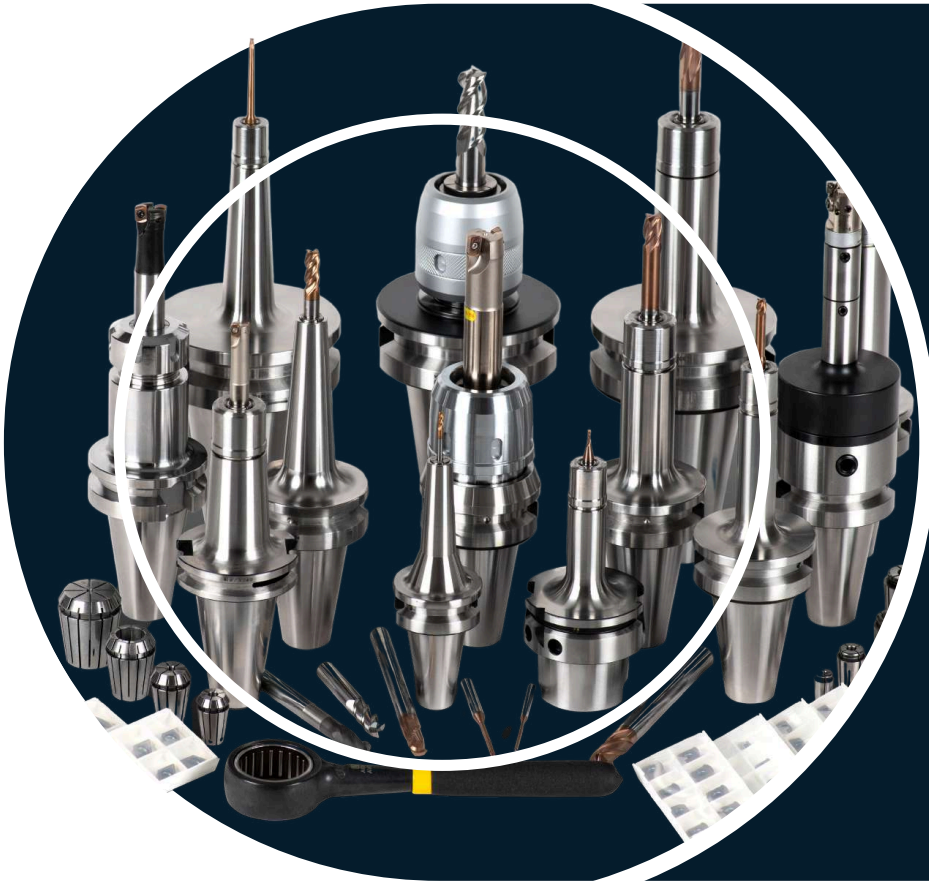



# İçindekiler

---

- Parmak Freze
- Kılavuz
- Takma Uç
- Takım Tutucu
- Hassas Bara
- Karbür Gövde
- Tarama Kafası
- Hızlı Bağlama Sistemi



# Parmak Freze

- GX (60HRc)
- GH (55HRc)
- GS (45HRc)
- GA (Alüminyum)
- GD (Grafit)
- GP (35HRc)



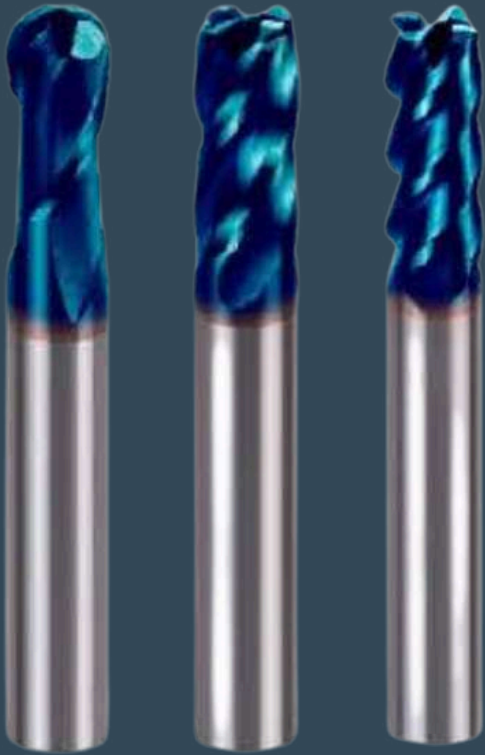

60 HRC  
GX SERİ

genco  
makina

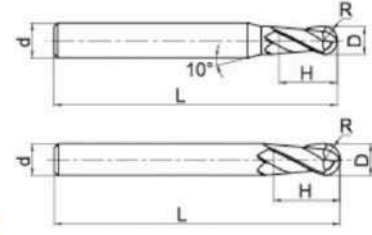

Ürün Kodu	D	R	H	L	d
GXSB 2010	1	0.5	2	60	4
GXSB 2010-6			2	60	6
GXSB 2015	1.5	0.75	3	60	4
GXSB 2015-6			3	60	6
GXSB 2020	2	1	4	60	4
GXSB 2020-6			4	60	6
GXSB 2030	3	1.5	6	60	3
GXSB 2030-6			6	60	6
GXSB 2040	4	2	8	60	4
GXLB 2040			8	75	4
GXSB 2040-6			8	60	6
GXSB 2050	5	2.5	10	75	6
GXSB 2050-5			10	75	5
GXSB 2060	6	3	9	60	6
GXMB 2060			9	75	6
GXLB 2060			9	100	6
GXSB 2080	8	4	12	60	8
GXMB 2080			12	75	8
GXLB 2080			12	100	8

Ürün Kodu	D	R	H	L	d
GXSB 2100	10	5	15	75	10
GXLB 2100			15	100	10
GXSB 2120	12	6	18	75	12
GXLB 2120			18	100	12

genco  
makina

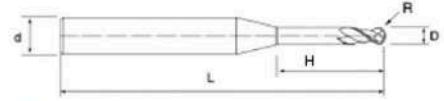

Ürün Kodu	D	R	H	L	d
GXRB 2002-005	0.2	0.1	0.5	50	4
GXRB 2002-010			1	50	4
GXRB 2002-015			1.5	50	4
GXRB 2002-020	0.3	0.15	2	50	4
GXRB 2003-005			0.5	50	4
GXRB 2003-010			1	50	4
GXRB 2003-020	0.4	0.2	2	50	4
GXRB 2003-030			3	50	4
GXRB 2004-010			1	50	4
GXRB 2004-020	0.5	0.25	2	50	4
GXRB 2004-030			3	50	4
GXRB 2004-040			4	50	4
GXRB 2005-010	0.6	0.3	1	50	4
GXRB 2005-020			2	50	4
GXRB 2005-030			3	50	4
GXRB 2005-040	0.8	0.4	4	50	4
GXRB 2005-050			5	50	4
GXRB 2005-060			6	50	4
GXRB 2005-080	1	0.5	8	50	4
GXRB 2006-010			1	50	4
GXRB 2006-020			2	50	4
GXRB 2006-030	1.5	0.75	3	50	4
GXRB 2006-040			4	50	4
GXRB 2006-050			5	50	4
GXRB 2006-060	1	0.5	6	50	4
GXRB 2006-080			8	50	4
GXRB 2008-010			10	50	4
GXRB 2008-020	1.5	0.75	12	50	4
GXRB 2008-030			4	50	4
GXRB 2008-040			5	50	4
GXRB 2008-050	1	0.5	6	50	4
GXRB 2008-060			8	50	4
GXRB 2008-080			10	50	4
GXRB 2008-100	1.5	0.75	12	50	4
GXRB 2008-120			4	50	4
GXRB 2010-040			6	50	4
GXRB 2010-060	1	0.5	8	50	4
GXRB 2010-080			10	50	4
GXRB 2010-100			12	50	4
GXRB 2010-120	1.5	0.75	14	50	4
GXRB 2010-140			16	50	4
GXRB 2010-160			20	50	4
GXRB 2010-200	1	0.5	6	50	4
GXRB 2015-060			8	50	4
GXRB 2015-080			10	50	4
GXRB 2015-100	1.5	0.75	12	50	4
GXRB 2015-120			14	50	4
GXRB 2015-140			16	50	4
GXRB 2015-160	1	0.5	20	50	4
GXRB 2015-200			6	50	4

Ürün Kodu	D	R	H	L	d
GXRB 2020-060	2	1	6	50	4
GXRB 2020-080			8	50	4
GXRB 2020-100			10	50	4
GXRB 2020-120	3	1.5	12	50	4
GXRB 2020-140			14	50	4
GXRB 2020-160			16	50	4
GXRB 2020-200	4	2	20	50	4
GXRB 2020-250			25	60	4
GXRB 2030-100			10	60	6
GXRB 2030-120	5	2.5	12	60	6
GXRB 2030-120-4			12	50	4
GXRB 2030-140			14	60	6
GXRB 2030-160	1	1	16	60	6
GXRB 2030-160-4			16	50	4
GXRB 2030-200			20	60	6
GXRB 2030-200-4	4	2	20	50	4
GXRB 2030-250			25	75	6
GXRB 2030-300			30	75	6
GXRB 2030-350	5	2.5	35	75	6
GXRB 2040-120			12	60	6
GXRB 2040-160			16	60	6
GXRB 2040-200	4	2	20	60	6
GXRB 2040-250			25	75	6
GXRB 2040-300			30	75	6
GXRB 2040-350	5	2.5	35	75	6
GXRB 2040-400			40	75	6
GXRB 2050-160			16	60	6
GXRB 2050-200	1	1	20	60	6
GXRB 2050-300			30	75	6
GXRB 2050-400			40	75	6

genco  
makina

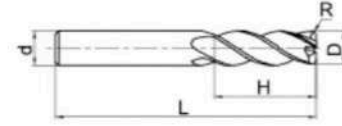
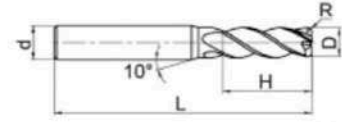

Ürün Kodu	D	R	H	L	d
GXSC 4030R02	3	0.2	8	60	3
GXSC 4030R05	3	0.5	8	60	3
GXLC 4030R05			8	75	3
GXSC 4030R10	3	1	8	60	3
GXSC 4040R02	4	0.2	8	60	4
GXLC 4040R02			8	75	4
GXSC 4040R05	4	0.5	8	60	4
GXLC 4040R05			8	75	4
GXSC 4040R10	4	1	8	60	4
GXLC 4040R10			8	75	4
GXSC 4050R05	5	0.5	15	75	6
GXSC 4050R05-5			10	75	5
GXSC 4050R10	5	1	15	75	6
GXSC 4050R10-5			10	75	5
GXSC 4060R02	6	0.2	12	60	6
GXMC 4060R02			12	75	6
GXLC 4060R02			12	100	6
GXSC 4060R03	6	0.3	12	60	6
GXMC 4060R03			12	75	6
GXLC 4060R03			12	100	6
GXSC 4060R05	6	0.5	12	60	6
GXMC 4060R05			12	75	6
GXLC 4060R05			12	100	6
GXSC 4060R10	6	1	12	60	6
GXMC 4060R10			12	75	6
GXLC 4060R10			12	100	6
GXSC 4080R02	8	0.2	16	60	8
GXLC 4080R02			16	100	8
GXSC 4080R05	8	0.5	16	60	8
GXMC 4080R05			16	75	8
GXLC 4080R05			16	100	8
GXSC 4080R10	8	1	16	60	8
GXMC 4080R10			16	75	8
GXLC 4080R10			16	100	8

Ürün Kodu	D	R	H	L	d
GXSC 4100R05	10	0.5	20	75	10
GXLC 4100R05			20	100	10
GXSC 4100R10	10	1	20	75	10
GXLC 4100R10			20	100	10
GXSC 4120R05	12	0.5	24	75	12
GXLC 4120R05			24	100	12
GXSC 4120R10	12	1	24	75	12
GXLC 4120R10			24	100	12

genco  
makina

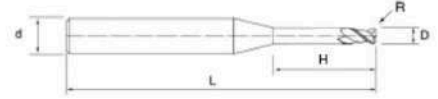

Ürün Kodu	D	R	H	L	d
GXRC 2005-005-010	0.5	0.05	1	50	4
GXRC 2005-005-020			2	50	4
GXRC 2005-005-030			3	50	4
GXRC 2005-005-040			4	50	4
GXRC 2005-005-050			5	50	4
GXRC 2005-005-060			6	50	4
GXRC 2005-005-080			8	50	4
GXRC 2005-01-010			0.5	0.1	1
GXRC 2005-01-020	2	50			4
GXRC 2005-01-030	3	50			4
GXRC 2005-01-040	4	50			4
GXRC 2005-01-050	5	50			4
GXRC 2005-01-060	6	50			4
GXRC 2005-01-080	8	50			4
GXRC 2006-01-010	0.6	0.1			1
GXRC 2006-01-020			2	50	4
GXRC 2006-01-030			3	50	4
GXRC 2006-01-040			4	50	4
GXRC 2006-01-050			5	50	4
GXRC 2006-01-060			6	50	4
GXRC 2006-01-080			8	50	4
GXRC 2006-02-010			0.6	0.2	1
GXRC 2006-02-020	2	50			4
GXRC 2006-02-030	3	50			4
GXRC 2006-02-040	4	50			4
GXRC 2006-02-050	5	50			4
GXRC 2006-02-060	6	50			4
GXRC 2006-02-080	8	50			4
GXRC 2008-01-020	0.8	0.1			2
GXRC 2008-01-040			4	50	4
GXRC 2008-01-060			6	50	4
GXRC 2008-01-080			8	50	4
GXRC 2008-01-100			10	50	4
GXRC 2008-01-120			12	50	4
GXRC 2008-02-020	0.8	0.2	2	50	4
GXRC 2008-02-040			4	50	4
GXRC 2008-02-060			6	50	4
GXRC 2008-02-080			8	50	4
GXRC 2008-02-100			10	50	4
GXRC 2008-02-120			12	50	4

Ürün Kodu	D	R	H	L	d
GXRC 2010-01-040	1	0.1	4	50	4
GXRC 2010-01-060			6	50	4
GXRC 2010-01-080			8	50	4
GXRC 2010-01-100			10	50	4
GXRC 2010-01-120			12	50	4
GXRC 2010-01-140			14	50	4
GXRC 2010-01-160			16	50	4
GXRC 2010-01-200			20	50	4
GXRC 2010-02-040	1	0.2	4	50	4
GXRC 2010-02-060			6	50	4
GXRC 2010-02-080			8	50	4
GXRC 2010-02-100			10	50	4
GXRC 2010-02-120			12	50	4
GXRC 2010-02-140			14	50	4
GXRC 2010-02-160			16	50	4
GXRC 2010-02-200			20	50	4
GXRC 2015-02-040	1.5	0.2	4	50	4
GXRC 2015-02-060			6	50	4
GXRC 2015-02-080			8	50	4
GXRC 2015-02-100			10	50	4
GXRC 2015-02-120			12	50	4
GXRC 2015-02-140			14	50	4
GXRC 2015-02-160			16	50	4
GXRC 2015-02-200			20	50	4
GXRC 2015-05-040	1.5	0.5	4	50	4
GXRC 2015-05-060			6	50	4
GXRC 2015-05-080			8	50	4
GXRC 2015-05-100			10	50	4
GXRC 2015-05-120			12	50	4
GXRC 2015-05-160			16	50	4
GXRC 2015-05-200	20	50	4		

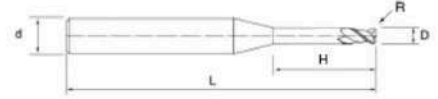

Ürün Kodu	D	R	H	L	d
GXRC 2025-02-080	2.5	0.2	8	50	4
GXRC 2025-02-100			10	50	4
GXRC 2025-02-120			12	50	4
GXRC 2025-02-160			16	50	4
GXRC 2025-02-200			20	50	4
GXRC 2025-02-250			25	60	4
GXRC 2025-05-080	2.5	0.5	8	50	4
GXRC 2025-05-100			10	50	4
GXRC 2025-05-120			12	50	4
GXRC 2025-05-160			16	50	4
GXRC 2025-05-200			20	50	4
GXRC 2025-05-250			25	60	4
GXRC 2020-02-040	2	0.2	4	50	4
GXRC 2020-02-060			6	50	4
GXRC 2020-02-080			8	50	4
GXRC 2020-02-100			10	50	4
GXRC 2020-02-120			12	50	4
GXRC 2020-02-140			14	50	4
GXRC 2020-02-160			16	50	4
GXRC 2020-02-200			20	50	4
GXRC 2020-02-250			25	60	4
GXRC 2020-05-040			2	0.5	4
GXRC 2020-05-060	6	50			4
GXRC 2020-05-080	8	50			4
GXRC 2020-05-100	10	50			4
GXRC 2020-05-120	12	50			4
GXRC 2020-05-140	14	50			4
GXRC 2020-05-160	16	50			4
GXRC 2020-05-200	20	50			4
GXRC 2020-05-250	25	60			4

Ürün Kodu	D	R	H	L	d		
GXRC 2030-02-080	3	0.2	8	60	6		
GXRC 2030-02-100			10	60	6		
GXRC 2030-02-120			12	60	6		
GXRC 2030-02-140			14	60	6		
GXRC 2030-02-160			16	60	6		
GXRC 2030-02-200			20	60	6		
GXRC 2030-02-250			25	75	6		
GXRC 2030-02-300			30	75	6		
GXRC 2030-02-350			35	75	6		
GXRC 2030-02-400			40	75	6		
GXRC 2030-05-080	3	0.5	8	60	6		
GXRC 2030-05-100			10	60	6		
GXRC 2030-05-120			12	60	6		
GXRC 2030-05-140			14	60	6		
GXRC 2030-05-160			16	60	6		
GXRC 2030-05-200			20	60	6		
GXRC 2030-05-250			25	75	6		
GXRC 2030-05-300			30	75	6		
GXRC 2030-05-350			35	75	6		
GXRC 2030-05-400			40	75	6		
GXRC 2040-02-100	4	0.2	10	60	6		
GXRC 2040-02-120			12	60	6		
GXRC 2040-02-160			16	60	6		
GXRC 2040-02-200			20	60	6		
GXRC 2040-02-250			25	75	6		
GXRC 2040-02-300			30	75	6		
GXRC 2040-02-350			35	75	6		
GXRC 2040-02-400			40	75	6		
GXRC 2040-05-100			4	0.5	10	60	6
GXRC 2040-05-120					12	60	6
GXRC 2040-05-160	16	60			6		
GXRC 2040-05-200	20	60			6		
GXRC 2040-05-250	25	75			6		
GXRC 2040-05-300	30	75			6		
GXRC 2040-05-350	35	75			6		
GXRC 2040-05-400	40	75			6		

genco  
makina

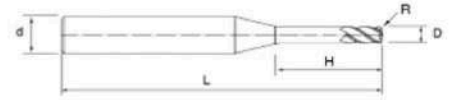

Ürün Kodu	D	R	H	L	d
GXRC 4010-01-040	1	0.1	4	50	4
GXRC 4010-01-060			6	50	4
GXRC 4010-01-080			8	50	4
GXRC 4010-01-100			10	50	4
GXRC 4010-01-120			12	50	4
GXRC 4010-01-140			14	50	4
GXRC 4010-01-160			16	50	4
GXRC 4010-01-200			20	50	4
GXRC 4010-02-040	1	0.2	4	50	4
GXRC 4010-02-060			6	50	4
GXRC 4010-02-080			8	50	4
GXRC 4010-02-100			10	50	4
GXRC 4010-02-120			12	50	4
GXRC 4010-02-140			14	50	4
GXRC 4010-02-160			16	50	4
GXRC 4010-02-200			20	50	4
GXRC 4015-02-040	1.5	0.2	4	50	4
GXRC 4015-02-060			6	50	4
GXRC 4015-02-080			8	50	4
GXRC 4015-02-100			10	50	4
GXRC 4015-02-120			12	50	4
GXRC 4015-02-140			14	50	4
GXRC 4015-02-160			16	50	4
GXRC 4015-02-200			20	50	4
GXRC 4015-05-040	1.5	0.5	4	50	4
GXRC 4015-05-060			6	50	4
GXRC 4015-05-080			8	50	4
GXRC 4015-05-100			10	50	4
GXRC 4015-05-120			12	50	4
GXRC 4015-05-140			14	50	4
GXRC 4015-05-160			16	50	4
GXRC 4015-05-200			20	50	4
GXRC 4020-02-040	2	0.2	4	50	4
GXRC 4020-02-060			6	50	4
GXRC 4020-02-080			8	50	4
GXRC 4020-02-100			10	50	4
GXRC 4020-02-120			12	50	4
GXRC 4020-02-140			14	50	4
GXRC 4020-02-160			16	50	4
GXRC 4020-02-200			20	50	4
GXRC 4020-02-250	25	60	4		
GXRC 4020-05-040	2	0.5	4	50	4
GXRC 4020-05-060			6	50	4
GXRC 4020-05-080			8	50	4
GXRC 4020-05-100			10	50	4
GXRC 4020-05-120			12	50	4
GXRC 4020-05-140			14	50	4
GXRC 4020-05-160			16	50	4
GXRC 4020-05-200			20	50	4
GXRC 4020-05-250	25	60	4		

Ürün Kodu	D	R	H	L	d
GXRC 4025-02-080	2.5	0.2	8	50	4
GXRC 4025-02-100			10	50	4
GXRC 4025-02-120			12	50	4
GXRC 4025-02-160			16	50	4
GXRC 4025-02-200			20	50	4
GXRC 4025-02-250			25	60	4
GXRC 4025-05-080	2.5	0.5	8	50	4
GXRC 4025-05-100			10	50	4
GXRC 4025-05-120			12	50	4
GXRC 4025-05-160			16	50	4
GXRC 4025-05-200			20	50	4
GXRC 4025-05-250			25	60	4
GXRC 4030-02-080	3	0.2	8	60	6
GXRC 4030-02-100			10	60	6
GXRC 4030-02-120			12	60	6
GXRC 4030-02-120-4			12	50	4
GXRC 4030-02-140			14	60	6
GXRC 4030-02-160			16	60	6
GXRC 4030-02-160-4			16	50	4
GXRC 4030-02-200			20	60	6
GXRC 4030-02-200-4			20	50	4
GXRC 4030-02-250			25	75	6
GXRC 4030-02-300			30	75	6
GXRC 4030-02-350			35	75	6
GXRC 4030-02-400	40	75	6		
GXRC 4030-05-080	3	0.5	8	60	6
GXRC 4030-05-100			10	60	6
GXRC 4030-05-120			12	60	6
GXRC 4030-05-120-4			12	50	4
GXRC 4030-05-140			14	60	6
GXRC 4030-05-160			16	60	6
GXRC 4030-05-160-4			16	50	4
GXRC 4030-05-200			20	60	6
GXRC 4030-05-200-4			20	50	4
GXRC 4030-05-250			25	75	6
GXRC 4030-05-300			30	75	6
GXRC 4030-05-350			35	75	6
GXRC 4030-05-400	40	75	6		

genco  
makina

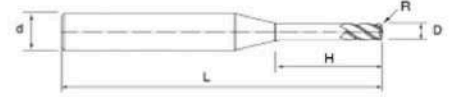

Ürün Kodu	D	R	H	L	d
GXRC 4040-02-100	4	0.2	10	60	6
GXRC 4040-02-120			12	60	6
GXRC 4040-02-160			16	60	6
GXRC 4040-02-200			20	60	6
GXRC 4040-02-250			25	75	6
GXRC 4040-02-300			30	75	6
GXRC 4040-02-350			35	75	6
GXRC 4040-02-400			40	75	6
GXRC 4040-05-100	4	0.5	10	60	6
GXRC 4040-05-120			12	60	6
GXRC 4040-05-160			16	60	6
GXRC 4040-05-200			20	60	6
GXRC 4040-05-250			25	75	6
GXRC 4040-05-300			30	75	6
GXRC 4040-05-350			35	75	6
GXRC 4040-05-400			40	75	6

Ürün Kodu	D	R	H	L	d
GXRC 4050-05-200	5	0.5	20	60	6
GXRC 4050-05-250			25	75	6
GXRC 4050-05-300			30	75	6
GXRC 4050-05-400			40	75	6

genco  
makina

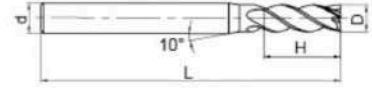

Ürün Kodu	D	R	H	L	d
GXSS 4010	1	-	2.5	50	4
GXSS 4015	1.5	-	4	50	4
GXSS 4020	2	-	5	50	4
GXSS 4025	2.5	-	6	50	4
GXSS 4030	3	-	10	60	3
GXLS 4030	3	-	10	75	3
GXSS 4040	4	-	11	60	4
GXLS 4040	4	-	15	75	4
GXSS 4050	5	-	13	60	6
GXMS 4050-5	5	-	13	75	5
GXSS 4060	6	-	15	60	6
GXLS 4060	6	-	20	100	6
GXSS 4080	8	-	20	60	8
GXLS 4080	8	-	25	100	8

Ürün Kodu	D	R	H	L	d
GXSS 4100	10	-	25	75	10
GXLS 4100			30	100	10
GXSS 4120	12	-	30	75	12
GXLS 4120			35	100	12

genco  
makina



Ürün Kodu	D	R	H	L	d
GXRS 2002-005	0.2	-	0.5	50	4
GXRS 2002-010			1	50	4
GXRS 2002-015			1.5	50	4
GXRS 2002-020	0.3	-	2	50	4
GXRS 2003-005			0.5	50	4
GXRS 2003-010			1	50	4
GXRS 2003-020	0.4	-	2	50	4
GXRS 2003-030			3	50	4
GXRS 2004-010			1	50	4
GXRS 2004-020	0.5	-	2	50	4
GXRS 2004-030			3	50	4
GXRS 2004-040			4	50	4
GXRS 2005-010	0.6	-	1	50	4
GXRS 2005-020			2	50	4
GXRS 2005-030			3	50	4
GXRS 2005-040	0.7	-	4	50	4
GXRS 2005-050			5	50	4
GXRS 2005-060			6	50	4
GXRS 2005-080	0.8	-	8	50	4
GXRS 2005-100			10	50	4
GXRS 2005-120			12	50	4
GXRS 2006-010	0.9	-	1	50	4
GXRS 2006-020			2	50	4
GXRS 2006-030			3	50	4
GXRS 2006-040	1.0	-	4	50	4
GXRS 2006-050			5	50	4
GXRS 2006-060			6	50	4
GXRS 2006-080	1.2	-	8	50	4
GXRS 2006-100			10	50	4
GXRS 2008-010			1	50	4
GXRS 2008-020	1.5	-	2	50	4
GXRS 2008-030			3	50	4
GXRS 2008-040			4	50	4
GXRS 2008-050	1.8	-	5	50	4
GXRS 2008-060			6	50	4
GXRS 2008-080			8	50	4
GXRS 2008-100	2.0	-	10	50	4
GXRS 2008-120			12	50	4
GXRS 2010-040			4	50	4
GXRS 2010-060	2.5	-	6	50	4
GXRS 2010-080			8	50	4
GXRS 2010-100			10	50	4
GXRS 2010-120	3.0	-	12	50	4
GXRS 2010-140			14	50	4
GXRS 2010-160			16	50	4
GXRS 2010-200	20	50	4		

Ürün Kodu	D	R	H	L	d
GXRS 2015-040	1.5	-	4	50	4
GXRS 2015-060			6	50	4
GXRS 2015-080			8	50	4
GXRS 2015-100	2.0	-	10	50	4
GXRS 2015-120			12	50	4
GXRS 2015-140			14	50	4
GXRS 2015-160	2.5	-	16	50	4
GXRS 2015-200			20	50	4
GXRS 2020-040			6	50	4
GXRS 2020-060	3.0	-	6	50	4
GXRS 2020-080			8	50	4
GXRS 2020-100			10	50	4
GXRS 2020-120	3.5	-	12	50	4
GXRS 2020-140			14	50	4
GXRS 2020-160			16	50	4
GXRS 2020-200	4.0	-	20	50	4
GXRS 2020-250			25	60	4
GXRS 2025-080			8	50	4
GXRS 2025-100	4.5	-	10	50	4
GXRS 2025-120			12	50	4
GXRS 2025-160			16	50	4
GXRS 2025-200	5.0	-	20	50	4
GXRS 2025-250			25	60	4
GXRS 2030-100			10	60	6
GXRS 2030-120	6.0	-	12	60	6
GXRS 2030-160			16	60	6
GXRS 2030-200			20	60	6
GXRS 2030-250	7.0	-	25	75	6
GXRS 2030-300			30	75	6
GXRS 2030-350			35	75	6
GXRS 2030-400	8.0	-	40	75	6
GXRS 2040-100			10	60	6
GXRS 2040-120			12	60	6
GXRS 2040-160	9.0	-	16	60	6
GXRS 2040-200			20	60	6
GXRS 2040-250			25	75	6
GXRS 2040-300	10.0	-	30	75	6
GXRS 2040-350			35	75	6
GXRS 2040-400			40	75	6

genco  
makina

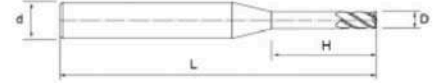

Ürün Kodu	D	R	H	L	d		
GXRS 4010-040	1	-	4	50	4		
GXRS 4010-060			6	50	4		
GXRS 4010-080			8	50	4		
GXRS 4010-100			10	50	4		
GXRS 4010-120			12	50	4		
GXRS 4010-140			14	50	4		
GXRS 4010-160			16	50	4		
GXRS 4010-200			20	50	4		
GXRS 4015-040			1.5	-	4	50	4
GXRS 4015-060					6	50	4
GXRS 4015-080	8	50			4		
GXRS 4015-100	10	50			4		
GXRS 4015-120	12	50			4		
GXRS 4015-140	14	50			4		
GXRS 4015-160	16	50			4		
GXRS 4015-200	20	50			4		
GXRS 4020-040	2	-			4	50	4
GXRS 4020-060					6	50	4
GXRS 4020-080			8	50	4		
GXRS 4020-100			10	50	4		
GXRS 4020-120			12	50	4		
GXRS 4020-140			14	50	4		
GXRS 4020-160			16	50	4		
GXRS 4020-200			20	50	4		
GXRS 4020-250			25	60	4		
GXRS 4025-080			2.5	-	8	50	4
GXRS 4025-100	10	50			4		
GXRS 4025-120	12	50			4		
GXRS 4025-160	16	50			4		
GXRS 4025-200	20	50			4		
GXRS 4025-250	25	60			4		

Ürün Kodu	D	R	H	L	d		
GXRS 4030-080	3	-	8	60	6		
GXRS 4030-100			10	60	6		
GXRS 4030-120			12	60	6		
GXRS 4030-140			14	60	6		
GXRS 4030-160			16	60	6		
GXRS 4030-200			20	60	6		
GXRS 4030-250			25	75	6		
GXRS 4030-300			30	75	6		
GXRS 4030-350			35	75	6		
GXRS 4040-100			4	-	10	60	6
GXRS 4040-120	12	60			6		
GXRS 4040-160	16	60			6		
GXRS 4040-200	20	60			6		
GXRS 4040-250	25	75			6		
GXRS 4040-300	30	75			6		
GXRS 4040-350	35	75			6		
GXRS 4040-400	40	75			6		
GXRS 4050-200	5	-			20	60	6
GXRS 4050-250					25	75	6
GXRS 4050-300			30	75	6		
GXRS 4050-400			40	75	6		





55 HRC  
GH SERİ

genco  
makina

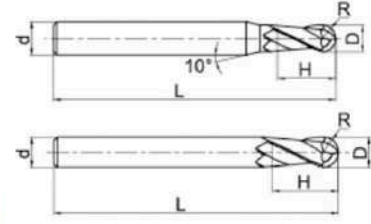
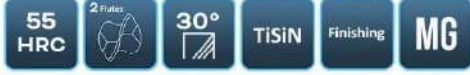

Ürün Kodu	D	R	H	L	d
GHSB 2040	4	2	8	60	4
GHLB 2040			8	75	4
GHSB 2050-5	5	2.5	8	75	5
GHSB 2060	6	3	9	60	6
GHLB 2060			9	100	6
GHSB 2080	8	4	12	60	8
GHLB 2080			12	100	8

Ürün Kodu	D	R	H	L	d
GHSB 2100	10	5	15	75	10
GHLB 2100			15	100	10
GHSB 2120	12	6	18	75	12
GHLB 2120			18	100	12

genco  
makina

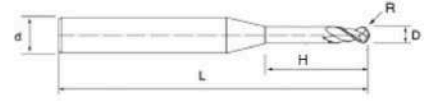
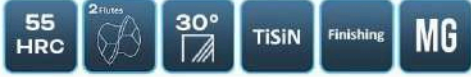

Ürün Kodu	D	R	H	L	d
GHRB 2002-005	0.2	0.1	0.5	50	4
GHRB 2002-010			1	50	4
GHRB 2002-015			1.5	50	4
GHRB 2002-020	0.3	0.15	2	50	4
GHRB 2003-005			0.5	50	4
GHRB 2003-010			1	50	4
GHRB 2003-020	0.4	0.2	2	50	4
GHRB 2003-030			3	50	4
GHRB 2004-010			1	50	4
GHRB 2004-020	0.5	0.25	2	50	4
GHRB 2004-030			3	50	4
GHRB 2004-040			4	50	4
GHRB 2005-010	0.6	0.3	1	50	4
GHRB 2005-020			2	50	4
GHRB 2005-030			3	50	4
GHRB 2005-040	0.8	0.4	4	50	4
GHRB 2005-050			5	50	4
GHRB 2005-060			6	50	4
GHRB 2005-080	1	0.5	8	50	4
GHRB 2005-100			10	50	4
GHRB 2005-120			12	50	4
GHRB 2006-010	0.2	0.1	1	50	4
GHRB 2006-020			2	50	4
GHRB 2006-030			3	50	4
GHRB 2006-040	0.3	0.15	4	50	4
GHRB 2006-050			5	50	4
GHRB 2006-060			6	50	4
GHRB 2006-080	0.4	0.2	8	50	4
GHRB 2006-100			10	50	4
GHRB 2006-120			12	50	4
GHRB 2008-010	0.5	0.25	1	50	4
GHRB 2008-020			2	50	4
GHRB 2008-030			3	50	4
GHRB 2008-040	0.6	0.3	4	50	4
GHRB 2008-050			5	50	4
GHRB 2008-060			6	50	4
GHRB 2008-080	0.8	0.4	8	50	4
GHRB 2008-100			10	50	4
GHRB 2008-120			12	50	4
GHRB 2010-040	1	0.5	4	50	4
GHRB 2010-060			6	50	4
GHRB 2010-080			8	50	4
GHRB 2010-100	1.5	0.75	10	50	4
GHRB 2010-120			12	50	4
GHRB 2010-140			14	50	4
GHRB 2010-160	2	1	16	50	4
GHRB 2010-200			20	50	4

Ürün Kodu	D	R	H	L	d
GHRB 2015-040	1.5	0.75	4	50	4
GHRB 2015-060			6	50	4
GHRB 2015-080			8	50	4
GHRB 2015-100	2	1	10	50	4
GHRB 2015-120			12	50	4
GHRB 2015-140			14	50	4
GHRB 2015-160	3	1.5	16	50	4
GHRB 2015-200			20	50	4
GHRB 2020-040			4	50	4
GHRB 2020-060	4	2	6	50	4
GHRB 2020-080			8	50	4
GHRB 2020-100			10	50	4
GHRB 2020-120	5	2.5	12	50	4
GHRB 2020-140			14	50	4
GHRB 2020-160			16	50	4
GHRB 2020-200	6	3	20	50	4
GHRB 2020-250			25	60	4
GHRB 2030-080			8	60	6
GHRB 2030-100	7	3.5	10	60	6
GHRB 2030-120			12	60	6
GHRB 2030-120-4			12	50	4
GHRB 2030-140	8	4	14	60	6
GHRB 2030-160			16	60	6
GHRB 2030-160-4			16	50	4
GHRB 2030-200	9	4.5	20	60	6
GHRB 2030-200-4			20	50	4
GHRB 2030-250			25	75	6
GHRB 2030-300	10	5	30	75	6
GHRB 2030-350			35	75	6
GHRB 2040-100			10	60	6
GHRB 2040-120	11	5.5	12	60	6
GHRB 2040-160			16	60	6
GHRB 2040-200			20	60	6
GHRB 2040-250	12	6	25	75	6
GHRB 2040-300			30	75	6
GHRB 2040-350			35	75	6
GHRB 2040-400	13	6.5	40	75	6
GHRB 2050-160			16	60	6
GHRB 2050-200			20	60	6
GHRB 2050-300	14	7	30	75	6
GHRB 2050-400			40	75	6

genco  
makina

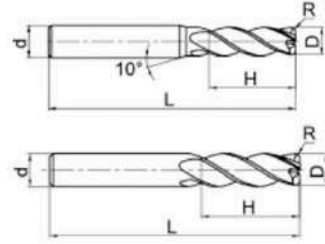

Ürün Kodu	D	R	H	L	d
GHSC 4030R05	3	0.5	8	60	3
GHSC 4040R05	4	0.5	8	60	4
GHLC 4040R05			8	75	4
GHSC 4050R05	5	0.5	15	75	6
GHSC 4050R05-5			10	75	5
GHSC 4050R10	5	1	15	75	6
GHSC 4050R10-5			10	75	5
GHSC 4060R05	6	0.5	12	60	6
GHLC 4060R05			12	100	6
GHSC 4060R10	6	1	12	60	6
GHLC 4060R10			12	100	6
GHSC 4080R05	8	0.5	16	60	8
GHLC 4080R05			16	100	8
GHSC 4080R10	8	1	16	60	8
GHLC 4080R10			16	100	8
GHXC 4080R10			16	120	8

Ürün Kodu	D	R	H	L	d
GHSC 4100R05	10	0.5	20	75	10
GHLC 4100R05			20	100	10
GHSC 4100R10	10	1	20	75	10
GHLC 4100R10			20	100	10
GHXC 4100R10			20	130	10
GHSC 4120R05	12	0.5	24	75	12
GHLC 4120R05			24	100	12
GHSC 4120R10	12	1	24	75	12
GHLC 4120R10			24	100	12

genco  
makina

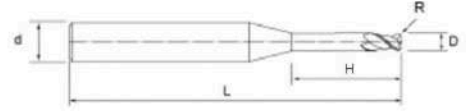

Ürün Kodu	D	R	H	L	d		
GHRC 2005-005-010	0.5	0.05	1	50	4		
GHRC 2005-005-020			2	50	4		
GHRC 2005-005-030			3	50	4		
GHRC 2005-005-040			4	50	4		
GHRC 2005-005-050			5	50	4		
GHRC 2005-005-060			6	50	4		
GHRC 2005-005-080			8	50	4		
GHRC 2005-01-010			0.5	0.1	1	50	4
GHRC 2005-01-020	2	50			4		
GHRC 2005-01-030	3	50			4		
GHRC 2005-01-040	4	50			4		
GHRC 2005-01-050	5	50			4		
GHRC 2005-01-060	6	50			4		
GHRC 2005-01-080	8	50			4		
GHRC 2006-01-010	0.6	0.1			1	50	4
GHRC 2006-01-020			2	50	4		
GHRC 2006-01-030			3	50	4		
GHRC 2006-01-040			4	50	4		
GHRC 2006-01-050			5	50	4		
GHRC 2006-01-060			6	50	4		
GHRC 2006-01-080			8	50	4		
GHRC 2006-02-010			0.6	0.2	1	50	4
GHRC 2006-02-020	2	50			4		
GHRC 2006-02-030	3	50			4		
GHRC 2006-02-040	4	50			4		
GHRC 2006-02-050	5	50			4		
GHRC 2006-02-060	6	50			4		
GHRC 2006-02-080	8	50			4		
GHRC 2008-01-020	0.8	0.1			2	50	4
GHRC 2008-01-040			4	50	4		
GHRC 2008-01-060			6	50	4		
GHRC 2008-01-080			8	50	4		
GHRC 2008-01-100			10	50	4		
GHRC 2008-01-120			12	50	4		
GHRC 2008-02-020			0.8	0.2	2	50	4
GHRC 2008-02-040					4	50	4
GHRC 2008-02-060	6	50			4		
GHRC 2008-02-080	8	50			4		
GHRC 2008-02-100	10	50			4		
GHRC 2008-02-120	12	50			4		

Ürün Kodu	D	R	H	L	d
GHRC 2010-01-040	1	0.1	4	50	4
GHRC 2010-01-060			6	50	4
GHRC 2010-01-080			8	50	4
GHRC 2010-01-100			10	50	4
GHRC 2010-01-120			12	50	4
GHRC 2010-01-140			14	50	4
GHRC 2010-01-160			16	50	4
GHRC 2010-01-200			20	50	4
GHRC 2010-02-040	1	0.2	4	50	4
GHRC 2010-02-060			6	50	4
GHRC 2010-02-080			8	50	4
GHRC 2010-02-100			10	50	4
GHRC 2010-02-120			12	50	4
GHRC 2010-02-140			14	50	4
GHRC 2010-02-160			16	50	4
GHRC 2010-02-200			20	50	4
GHRC 2015-02-040	1.5	0.2	4	50	4
GHRC 2015-02-060			6	50	4
GHRC 2015-02-080			8	50	4
GHRC 2015-02-100			10	50	4
GHRC 2015-02-120			12	50	4
GHRC 2015-02-140			14	50	4
GHRC 2015-02-160			16	50	4
GHRC 2015-02-200			20	50	4
GHRC 2015-05-040	1.5	0.5	4	50	4
GHRC 2015-05-060			6	50	4
GHRC 2015-05-080			8	50	4
GHRC 2015-05-100			10	50	4
GHRC 2015-05-120			12	50	4
GHRC 2015-05-160			16	50	4
GHRC 2015-05-200			20	50	4

genco  
makina

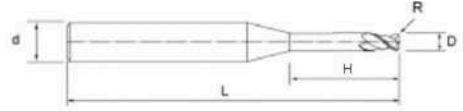

Ürün Kodu	D	R	H	L	d
GHRC 2025-02-080	2.5	0.2	8	50	4
GHRC 2025-02-100			10	50	4
GHRC 2025-02-120			12	50	4
GHRC 2025-02-160			16	50	4
GHRC 2025-02-200			20	50	4
GHRC 2025-02-250			25	60	4
GHRC 2025-05-080	2.5	0.5	8	50	4
GHRC 2025-05-100			10	50	4
GHRC 2025-05-120			12	50	4
GHRC 2025-05-160			16	50	4
GHRC 2025-05-200			20	50	4
GHRC 2025-05-250			25	60	4
GHRC 2020-02-040	2	0.2	4	50	4
GHRC 2020-02-060			6	50	4
GHRC 2020-02-080			8	50	4
GHRC 2020-02-100			10	50	4
GHRC 2020-02-120			12	50	4
GHRC 2020-02-140			14	50	4
GHRC 2020-02-160			16	50	4
GHRC 2020-02-200			20	50	4
GHRC 2020-02-250			25	60	4
GHRC 2020-05-040			2	0.5	4
GHRC 2020-05-060	6	50			4
GHRC 2020-05-080	8	50			4
GHRC 2020-05-100	10	50			4
GHRC 2020-05-120	12	50			4
GHRC 2020-05-140	14	50			4
GHRC 2020-05-160	16	50			4
GHRC 2020-05-200	20	50			4
GHRC 2020-05-250	25	60			4

Ürün Kodu	D	R	H	L	d		
GHRC 2030-02-080	3	0.2	8	60	6		
GHRC 2030-02-100			10	60	6		
GHRC 2030-02-120			12	60	6		
GHRC 2030-02-140			14	60	6		
GHRC 2030-02-160			16	60	6		
GHRC 2030-02-200			20	60	6		
GHRC 2030-02-250	3	0.5	25	75	6		
GHRC 2030-02-300			30	75	6		
GHRC 2030-02-350			35	75	6		
GHRC 2030-02-400			40	75	6		
GHRC 2030-05-080			3	0.5	8	60	6
GHRC 2030-05-100					10	60	6
GHRC 2030-05-120	12	60			6		
GHRC 2030-05-140	14	60			6		
GHRC 2030-05-160	16	60			6		
GHRC 2030-05-200	20	60			6		
GHRC 2030-05-250	25	75			6		
GHRC 2030-05-300	30	75			6		
GHRC 2030-05-350	35	75			6		
GHRC 2030-05-400	40	75			6		
GHRC 2040-02-100	4	0.2	10	60	6		
GHRC 2040-02-120			12	60	6		
GHRC 2040-02-160			16	60	6		
GHRC 2040-02-200			20	60	6		
GHRC 2040-02-250			25	75	6		
GHRC 2040-02-300			30	75	6		
GHRC 2040-02-350	4	0.5	35	75	6		
GHRC 2040-02-400			40	75	6		
GHRC 2040-05-100			4	0.5	10	60	6
GHRC 2040-05-120					12	60	6
GHRC 2040-05-160					16	60	6
GHRC 2040-05-200					20	60	6
GHRC 2040-05-250	25	75			6		
GHRC 2040-05-300	30	75			6		
GHRC 2040-05-350	35	75			6		
GHRC 2040-05-400	40	75			6		

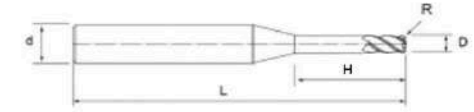

Ürün Kodu	D	R	H	L	d		
GHRC 4010-01-040	1	0.1	4	50	4		
GHRC 4010-01-060			6	50	4		
GHRC 4010-01-080			8	50	4		
GHRC 4010-01-100			10	50	4		
GHRC 4010-01-120			12	50	4		
GHRC 4010-01-140			14	50	4		
GHRC 4010-01-160			16	50	4		
GHRC 4010-01-200			20	50	4		
GHRC 4010-02-040			1	0.2	4	50	4
GHRC 4010-02-060					6	50	4
GHRC 4010-02-080	8	50			4		
GHRC 4010-02-100	10	50			4		
GHRC 4010-02-120	12	50			4		
GHRC 4010-02-140	14	50			4		
GHRC 4010-02-160	16	50			4		
GHRC 4010-02-200	20	50			4		
GHRC 4015-02-040	1.5	0.2			4	50	4
GHRC 4015-02-060					6	50	4
GHRC 4015-02-080			8	50	4		
GHRC 4015-02-100			10	50	4		
GHRC 4015-02-120			12	50	4		
GHRC 4015-02-140			14	50	4		
GHRC 4015-02-160			16	50	4		
GHRC 4015-02-200			20	50	4		
GHRC 4015-05-040			1.5	0.5	4	50	4
GHRC 4015-05-060					6	50	4
GHRC 4015-05-080	8	50			4		
GHRC 4015-05-100	10	50			4		
GHRC 4015-05-120	12	50			4		
GHRC 4015-05-140	14	50			4		
GHRC 4015-05-160	16	50			4		
GHRC 4015-05-200	20	50			4		
GHRC 4020-02-040	2	0.2			4	50	4
GHRC 4020-02-060					6	50	4
GHRC 4020-02-080			8	50	4		
GHRC 4020-02-100			10	50	4		
GHRC 4020-02-120			12	50	4		
GHRC 4020-02-140			14	50	4		
GHRC 4020-02-160			16	50	4		
GHRC 4020-02-200			20	50	4		
GHRC 4020-02-250			25	60	4		
GHRC 4020-05-040			2	0.5	4	50	4
GHRC 4020-05-060	6	50			4		
GHRC 4020-05-080	8	50			4		
GHRC 4020-05-100	10	50			4		
GHRC 4020-05-120	12	50			4		
GHRC 4020-05-140	14	50			4		
GHRC 4020-05-160	16	50			4		
GHRC 4020-05-200	20	50			4		
GHRC 4020-05-250	25	60	4				

Ürün Kodu	D	R	H	L	d		
GHRC 4025-02-080	2.5	0.2	8	50	4		
GHRC 4025-02-100			10	50	4		
GHRC 4025-02-120			12	50	4		
GHRC 4025-02-160			16	50	4		
GHRC 4025-02-200			20	50	4		
GHRC 4025-02-250			25	60	4		
GHRC 4025-05-080			2.5	0.5	8	50	4
GHRC 4025-05-100					10	50	4
GHRC 4025-05-120	12	50			4		
GHRC 4025-05-160	16	50			4		
GHRC 4025-05-200	20	50			4		
GHRC 4025-05-250	25	60			4		
GHRC 4030-02-080	3	0.2			8	60	6
GHRC 4030-02-100					10	60	6
GHRC 4030-02-120			12	60	6		
GHRC 4030-02-120-4			12	50	4		
GHRC 4030-02-140			14	60	6		
GHRC 4030-02-160			16	60	6		
GHRC 4030-02-160-4			16	50	4		
GHRC 4030-02-200			20	60	6		
GHRC 4030-02-200-4			20	50	4		
GHRC 4030-02-250			25	75	6		
GHRC 4030-02-300	3	0.5	30	75	6		
GHRC 4030-02-350			35	75	6		
GHRC 4030-02-400			40	75	6		
GHRC 4030-05-080			8	60	6		
GHRC 4030-05-100			10	60	6		
GHRC 4030-05-120			12	60	6		
GHRC 4030-05-120-4			12	50	4		
GHRC 4030-05-140			14	60	6		
GHRC 4030-05-160			16	60	6		
GHRC 4030-05-160-4			16	50	4		
GHRC 4030-05-200	20	60	6				
GHRC 4030-05-200-4	20	50	4				
GHRC 4030-05-250	25	75	6				
GHRC 4030-05-300	30	75	6				
GHRC 4030-05-350	35	75	6				
GHRC 4030-05-400	40	75	6				

genco  
makina

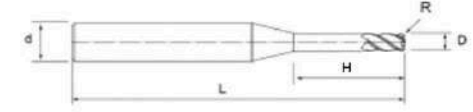

Ürün Kodu	D	R	H	L	d		
GHRC 4040-02-100	4	0.2	10	60	6		
GHRC 4040-02-120			12	60	6		
GHRC 4040-02-160			16	60	6		
GHRC 4040-02-200			20	60	6		
GHRC 4040-02-250			25	75	6		
GHRC 4040-02-300			30	75	6		
GHRC 4040-02-350			35	75	6		
GHRC 4040-02-400			40	75	6		
GHRC 4040-05-100			4	0.5	10	60	6
GHRC 4040-05-120					12	60	6
GHRC 4040-05-160	16	60			6		
GHRC 4040-05-200	20	60			6		
GHRC 4040-05-250	25	75			6		
GHRC 4040-05-300	30	75			6		
GHRC 4040-05-350	35	75			6		
GHRC 4040-05-400	40	75			6		

Ürün Kodu	D	R	H	L	d
GHRC 4050-05-200	5	0.5	20	60	6
GHRC 4050-05-250			25	75	6
GHRC 4050-05-300			30	75	6
GHRC 4050-05-400			40	75	6

genco  
makina

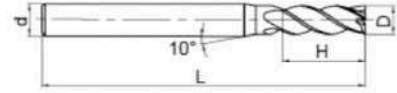

Ürün Kodu	D	R	H	L	d
GHSS 4040	4	-	11	60	4
GHLS 4040			15	75	4
GHSS 4050	5	-	13	60	6
GHSS 4060	6	-	15	60	6
GHLS 4060			20	100	6
GHSS 4080	8	-	20	60	8
GHLS 4080			25	100	8

Ürün Kodu	D	R	H	L	d
GHSS 4100	10	-	25	75	10
GHLS 4100			30	100	10
GHSS 4120	12	-	30	75	12
GHLS 4120			35	100	12

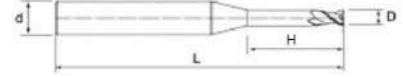

Ürün Kodu	D	R	H	L	d
GHR5 2002-005	0.2	-	0.5	50	4
GHR5 2002-010			1	50	4
GHR5 2002-015			1.5	50	4
GHR5 2002-020	0.3	-	2	50	4
GHR5 2003-005			0.5	50	4
GHR5 2003-010			1	50	4
GHR5 2003-020	0.4	-	2	50	4
GHR5 2003-030			3	50	4
GHR5 2004-010			1	50	4
GHR5 2004-020	0.5	-	2	50	4
GHR5 2004-030			3	50	4
GHR5 2004-040			4	50	4
GHR5 2005-010	0.6	-	1	50	4
GHR5 2005-020			2	50	4
GHR5 2005-030			3	50	4
GHR5 2005-040	0.8	-	4	50	4
GHR5 2005-050			5	50	4
GHR5 2005-060			6	50	4
GHR5 2005-080	1	-	8	50	4
GHR5 2005-100			10	50	4
GHR5 2005-120			12	50	4
GHR5 2006-010	0.2	-	1	50	4
GHR5 2006-020			2	50	4
GHR5 2006-030			3	50	4
GHR5 2006-040	0.3	-	4	50	4
GHR5 2006-050			5	50	4
GHR5 2006-060			6	50	4
GHR5 2006-080	0.4	-	8	50	4
GHR5 2006-100			10	50	4
GHR5 2008-010			1	50	4
GHR5 2008-020	0.5	-	2	50	4
GHR5 2008-030			3	50	4
GHR5 2008-040			4	50	4
GHR5 2008-050	0.6	-	5	50	4
GHR5 2008-060			6	50	4
GHR5 2008-080			8	50	4
GHR5 2008-100	0.8	-	10	50	4
GHR5 2008-120			12	50	4
GHR5 2010-040			4	50	4
GHR5 2010-060	1	-	6	50	4
GHR5 2010-080			8	50	4
GHR5 2010-100			10	50	4
GHR5 2010-120	1.5	-	12	50	4
GHR5 2010-140			14	50	4
GHR5 2010-160			16	50	4
GHR5 2010-200	20	50	4		

Ürün Kodu	D	R	H	L	d
GHR5 2015-040	1.5	-	4	50	4
GHR5 2015-060			6	50	4
GHR5 2015-080			8	50	4
GHR5 2015-100	2	-	10	50	4
GHR5 2015-120			12	50	4
GHR5 2015-140			14	50	4
GHR5 2015-160	2.5	-	16	50	4
GHR5 2015-200			20	50	4
GHR5 2020-040			6	50	4
GHR5 2020-060	3	-	6	50	4
GHR5 2020-080			8	50	4
GHR5 2020-100			10	50	4
GHR5 2020-120	4	-	12	50	4
GHR5 2020-140			14	50	4
GHR5 2020-160			16	50	4
GHR5 2020-200	2.5	-	20	50	4
GHR5 2020-250			25	60	4
GHR5 2025-080			8	50	4
GHR5 2025-100	3	-	10	50	4
GHR5 2025-120			12	50	4
GHR5 2025-160			16	50	4
GHR5 2025-200	4	-	20	50	4
GHR5 2025-250			25	60	4
GHR5 2030-100			10	60	6
GHR5 2030-120	1.5	-	12	60	6
GHR5 2030-160			16	60	6
GHR5 2030-200			20	60	6
GHR5 2030-250	2	-	25	75	6
GHR5 2030-300			30	75	6
GHR5 2030-350			35	75	6
GHR5 2030-400	2.5	-	40	75	6
GHR5 2040-100			10	60	6
GHR5 2040-120			12	60	6
GHR5 2040-160	3	-	16	60	6
GHR5 2040-200			20	60	6
GHR5 2040-250			25	75	6
GHR5 2040-300	4	-	30	75	6
GHR5 2040-350			35	75	6
GHR5 2040-400			40	75	6

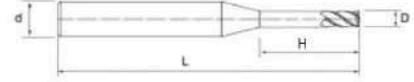

Ürün Kodu	D	R	H	L	d		
GHR5 4010-040	1	-	4	50	4		
GHR5 4010-060			6	50	4		
GHR5 4010-080			8	50	4		
GHR5 4010-100			10	50	4		
GHR5 4010-120			12	50	4		
GHR5 4010-140			14	50	4		
GHR5 4010-160			16	50	4		
GHR5 4010-200			20	50	4		
GHR5 4015-040			1.5	-	4	50	4
GHR5 4015-060					6	50	4
GHR5 4015-080	8	50			4		
GHR5 4015-100	10	50			4		
GHR5 4015-120	12	50			4		
GHR5 4015-140	14	50			4		
GHR5 4015-160	16	50			4		
GHR5 4015-200	20	50			4		
GHR5 4020-040	2	-			4	50	4
GHR5 4020-060					6	50	4
GHR5 4020-080			8	50	4		
GHR5 4020-100			10	50	4		
GHR5 4020-120			12	50	4		
GHR5 4020-140			14	50	4		
GHR5 4020-160			16	50	4		
GHR5 4020-200			20	50	4		
GHR5 4020-250			25	60	4		
GHR5 4025-080			2.5	-	8	50	4
GHR5 4025-100	10	50			4		
GHR5 4025-120	12	50			4		
GHR5 4025-160	16	50			4		
GHR5 4025-200	20	50			4		
GHR5 4025-250	25	60			4		

Ürün Kodu	D	R	H	L	d		
GHR5 4030-080	3	-	8	60	6		
GHR5 4030-100			10	60	6		
GHR5 4030-120			12	60	6		
GHR5 4030-140			14	60	6		
GHR5 4030-160			16	60	6		
GHR5 4030-200			20	60	6		
GHR5 4030-250			25	75	6		
GHR5 4030-300			30	75	6		
GHR5 4030-350			35	75	6		
GHR5 4040-100			4	-	10	60	6
GHR5 4040-120	12	60			6		
GHR5 4040-160	16	60			6		
GHR5 4040-200	20	60			6		
GHR5 4040-250	25	75			6		
GHR5 4040-300	30	75			6		
GHR5 4040-350	35	75			6		
GHR5 4040-400	40	75			6		
GHR5 4050-200	5	-			20	60	6
GHR5 4050-250					25	75	6
GHR5 4050-300			30	75	6		
GHR5 4050-400			40	75	6		

genco  
makina

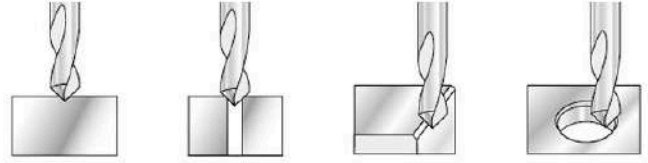

Ürün Kodu	D	$\theta$	L1	L	d
GSTH 2060-060-04	4	30	2	60	4
GSTH 2060-080-04			2	80	4
GSTH 2090-060-04	4	45	2	60	4
GSTH 2090-080-04			2	80	4
GSTH 2090-060-06	6	30	3	60	6
GSTH 2090-100-06			3	100	6
GSTH 2090-060-06	6	45	3	60	6
GSTH 2090-100-06			3	100	6
GSTH 4090-100-08	8	30	4	100	8
GSTH 4090-100-08	8	45	4	100	8

Ürün Kodu	D	$\theta$	L1	L	d
GSTH 4090-100-10	10	45	5	100	10
GSTH 4090-100-12	12	45	6	100	12



4.5 HRC  
GS SERİ

genco  
makina

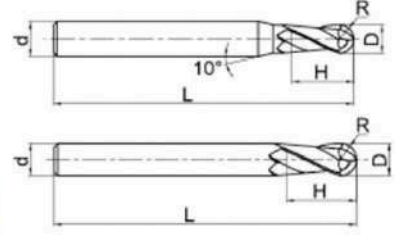

Ürün Kodu	D	R	H	L	d
GSSB 2010	1	0.5	2	50	4
GSSB 2015	1.5	0.75	3	50	4
GSSB 2020	2	1	4	50	4
GSSB 2030	3	1.5	6	60	3
GSSB 2030		1.5	6	75	3
GSSB 2030-4		1.5	6	50	4
GSSB 2040	4	2	8	60	4
GSLB 2040			8	75	4
GSSB 2050	5	2.5	10	50	6
GSSB 2050-5			10	50	5
GSMB 2050-5			10	75	5
GSSB 2060	6	3	9	60	6
GSMB 2060			9	75	6
GSLB 2060			9	100	6
GSSB 2080	8	4	12	60	8
GSLB 2080			12	100	8

Ürün Kodu	D	R	H	L	d
GSSB 2100	10	5	15	75	10
GSLB 2100			15	100	10
GSSB 2120	12	6	18	75	12
GSLB 2120			18	100	12

genco  
makina

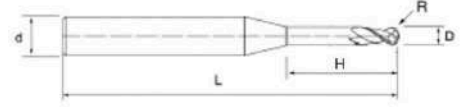

Ürün Kodu	D	R	H	L	d
GSRB 2005-010			1	50	4
GSRB 2005-020	0.5	0.25	2	50	4
GSRB 2005-040			4	50	4
GSRB 2006-020			2	50	4
GSRB 2006-040	0.6	0.3	4	50	4
GSRB 2008-020			2	50	4
GSRB 2008-040	0.8	0.4	4	50	4
GSRB 2008-060			6	50	4
GSRB 2010-040			4	50	4
GSRB 2010-060			6	50	4
GSRB 2010-080			8	50	4
GSRB 2010-100	1	0.5	10	50	4
GSRB 2010-120			12	50	4
GSRB 2010-160			16	50	4
GSRB 2010-200			20	50	4
GSRB 2015-040			4	50	4
GSRB 2015-060			6	50	4
GSRB 2015-080			8	50	4
GSRB 2015-100	1.5	0.75	10	50	4
GSRB 2015-120			12	50	4
GSRB 2015-160			16	50	4
GSRB 2015-200			20	50	4
GSRB 2020-040			4	50	4
GSRB 2020-060			6	50	4
GSRB 2020-080			8	50	4
GSRB 2020-100	2	1	10	50	4
GSRB 2020-120			12	50	4
GSRB 2020-140			14	50	4
GSRB 2020-160			16	50	4
GSRB 2020-200			20	50	4

Ürün Kodu	D	R	H	L	d
GSRB 2030-100			10	60	6
GSRB 2030-120			12	60	6
GSRB 2030-160	3		16	60	6
GSRB 2030-200			20	60	6
GSRB 2030-250			25	60	6
GSRB 2040-120			12	60	6
GSRB 2040-160	4	2	16	60	6
GSRB 2040-200			20	60	6
GSRB 2040-250			25	60	6

genco  
makina

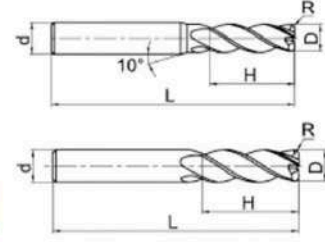

Ürün Kodu	D	R	H	L	d		
GSSC 4025R02	2.5	0.2	8	50	3		
GSLC 4025R05	2.5	0.5	8	50	3		
GSSC 4030R02	3	0.2	8	60	3		
GSLC 4030R02			8	75	3		
GSSC 4030R05	3	0.5	8	60	3		
GSLC 4030R05			8	75	3		
GSSC 4030R05-4			8	50	4		
GSSC 4030R10	3	1	8	60	3		
GSLC 4030R10			8	75	3		
GSSC 4040R02	4	0.2	8	60	4		
GSLC 4040R02			8	75	4		
GSSC 4040R05	4	0.5	8	60	4		
GSLC 4040R05			8	75	4		
GSSC 4040R10			4	1	8	60	4
GSLC 4040R10	8	75			4		
GSSC 4050R05	5	0.5	13	50	6		
GSSC 4050R05-5			13	50	5		
GSSC 4050R05-5			13	75	5		
GSSC 4050R10			13	50	6		
GSSC 4050R10-5			5	1	13	50	5
GSSC 4050R10-5					13	75	5
GSSC 4060R02	6	0.2	12	60	6		
GSMC 4060R02			12	75	6		
GSLC 4060R02			12	100	6		
GSSC 4060R05	6	0.5	12	60	6		
GSMC 4060R05			12	75	6		
GSLC 4060R05			12	100	6		
GSSC 4060R10			6	1	12	60	6
GSMC 4060R10	12	75			6		
GSLC 4060R10	12	100			6		
GSSC 4080R02	8	0.2	16	60	8		
GSLC 4080R02			16	100	8		
GSSC 4080R05	8	0.5	16	60	8		
GSLC 4080R05			16	100	8		
GSSC 4080R10			8	1	16	60	8
GSLC 4080R10	16	100			8		

Ürün Kodu	D	R	H	L	d
GSSC 4100R05	10	0.5	20	75	10
GSLC 4100R05			20	100	10
GSSC 4100R10	10	1	20	75	10
GSLC 4100R10			20	100	10
GSSC 4120R05	12	0.5	24	75	12
GSLC 4120R05			24	100	12
GSSC 4120R10	12	1	24	75	12
GSLC 4120R10			24	100	12

genco  
makina

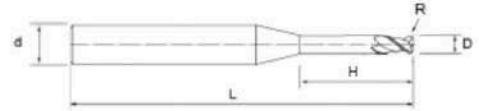

Ürün Kodu	D	R	H	L	d
GSRC 2005-005-010	0.5	0.05	1	50	4
GSRC 2005-005-020			2	50	4
GSRC 2005-005-040			4	50	4
GSRC 2006-01-020	0.6	0.1	2	50	4
GSRC 2006-01-040			4	50	4
GSRC 2008-02-020	0.8	0.2	2	50	4
GSRC 2008-02-040			4	50	4
GSRC 2008-02-060			6	50	4
GSRC 2010-02-040	1	0.2	4	50	4
GSRC 2010-02-060			6	50	4
GSRC 2010-02-080			8	50	4
GSRC 2010-02-100			10	50	4
GSRC 2010-02-120			12	50	4
GSRC 2010-02-160			16	50	4
GSRC 2010-02-200	1.5	0.2	20	50	4
GSRC 2015-02-040			4	50	4
GSRC 2015-02-060			6	50	4
GSRC 2015-02-080			8	50	4
GSRC 2015-02-100			10	50	4
GSRC 2015-02-120			12	50	4
GSRC 2015-02-160	2	0.2	16	50	4
GSRC 2015-02-200			20	50	4
GSRC 2020-02-040			4	50	4
GSRC 2020-02-060			6	50	4
GSRC 2020-02-080			8	50	4
GSRC 2020-02-100			10	50	4
GSRC 2020-02-120	2	0.5	12	50	4
GSRC 2020-02-160			16	50	4
GSRC 2020-02-200			20	50	4
GSRC 2020-05-040			4	50	4
GSRC 2020-05-060			6	50	4
GSRC 2020-05-080			8	50	4
GSRC 2020-05-100	2	0.5	10	50	4
GSRC 2020-05-120			12	50	4
GSRC 2020-05-160			16	50	4
GSRC 2020-05-200			20	50	4

Ürün Kodu	D	R	H	L	d
GSRC 2030-02-100	3	0.2	10	60	6
GSRC 2030-02-120			12	60	6
GSRC 2030-02-160			16	60	6
GSRC 2030-02-200			20	60	6
GSRC 2030-02-250	3	0.5	25	60	6
GSRC 2030-05-100			10	60	6
GSRC 2030-05-120			12	60	6
GSRC 2030-05-160			16	60	6
GSRC 2030-05-200	4	0.2	20	60	6
GSRC 2030-05-250			25	60	6
GSRC 2040-02-120			12	60	6
GSRC 2040-02-160			16	60	6
GSRC 2040-02-200	4	0.5	20	60	6
GSRC 2040-02-250			25	60	6
GSRC 2040-05-120			12	60	6
GSRC 2040-05-160			16	60	6
GSRC 2040-05-200	4	0.5	20	60	6
GSRC 2040-05-250			25	60	6

genco  
makina

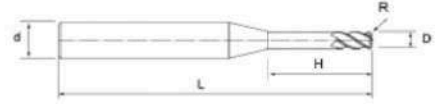

Ürün Kodu	D	R	H	L	d
GSRC 4010-02-040	1	0.2	4	50	4
GSRC 4010-02-060			6	50	4
GSRC 4010-02-080			8	50	4
GSRC 4010-02-100			10	50	4
GSRC 4010-02-120			12	50	4
GSRC 4010-02-160			16	50	4
GSRC 4010-02-200			20	50	4
GSRC 4015-02-060	1.5	0.2	6	50	4
GSRC 4015-02-080			8	50	4
GSRC 4015-02-100			10	50	4
GSRC 4015-02-120			12	50	4
GSRC 4015-02-160			16	50	4
GSRC 4015-02-200			20	50	4
GSRC 4020-02-060			2	0.2	6
GSRC 4020-02-080	8	50			4
GSRC 4020-02-100	10	50			4
GSRC 4020-02-120	12	50			4
GSRC 4020-02-160	16	50			4
GSRC 4020-02-200	20	50			4
GSRC 4020-05-060	2	0.5			6
GSRC 4020-05-080			8	50	4
GSRC 4020-05-100			10	50	4
GSRC 4020-05-120			12	50	4
GSRC 4020-05-160			16	50	4
GSRC 4020-05-200			20	50	4

Ürün Kodu	D	R	H	L	d
GSRC 4030-02-100	3	0.2	10	60	6
GSRC 4030-02-120			12	60	6
GSRC 4030-02-160			16	60	6
GSRC 4030-02-200			20	60	6
GSRC 4030-02-250			25	60	6
GSRC 4030-05-100	3	0.5	10	60	6
GSRC 4030-05-120			12	60	6
GSRC 4030-05-160			16	60	6
GSRC 4030-05-200			20	60	6
GSRC 4030-05-250			25	60	6
GSRC 4040-02-120	4	0.2	12	60	6
GSRC 4040-02-160			16	60	6
GSRC 4040-02-200			20	60	6
GSRC 4040-02-250			25	60	6
GSRC 4040-05-120			4	0.5	12
GSRC 4040-05-160	16	60			6
GSRC 4040-05-200	20	60			6
GSRC 4040-05-250	25	60			6

genco  
makina

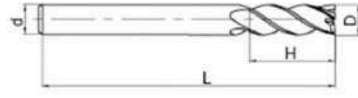
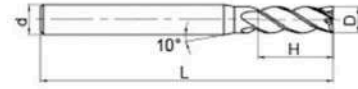

Ürün Kodu	D	R	H	L	d
GSSS 4010	1	-	3	50	4
GSSS 4015	1.5	-	4	50	4
GSSS 4020	2	-	6	50	4
GSSS 4025	2.5	-	6	50	4
GSSS 4030	3	-	8	60	3
GSLs 4030		-	8	75	3
GSSS 4030-4		-	8	50	4
GSSS 4040	4	-	11	60	4
GSLs 4040		-	11	75	4
GSSS 4050	5	-	13	50	6
GSSS 4050-5		-	13	50	5
GSMS 4050-5		-	13	75	5
GSSS 4060	6	-	15	60	6
GSMS 4060		-	20	75	6
GSLs 4060		-	20	100	6
GSSS 4080	8	-	20	60	8
GSLs 4080		-	25	100	8

Ürün Kodu	D	R	H	L	d
GSSS 4100	10	-	30	75	10
GSLs 4100		-	40	100	10
GSSS 4120	12	-	30	75	12
GSLs 4120		-	40	100	12
GSSS 4140	14	-	35	75	14
GSLs 4160	16	-	45	100	16

genco  
makina

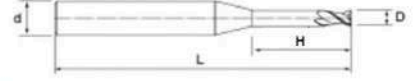

Ürün Kodu	D	R	H	L	d
GSRs 2005-010	0.5	-	1	50	4
GSRs 2005-020			2	50	4
GSRs 2005-040			4	50	4
GSRs 2006-020	0.6	-	2	50	4
GSRs 2006-040			4	50	4
GSRs 2008-020	0.8	-	2	50	4
GSRs 2008-040			4	50	4
GSRs 2008-060			6	50	4
GSRs 2010-040	1	-	4	50	4
GSRs 2010-060			6	50	4
GSRs 2010-080			8	50	4
GSRs 2010-100			10	50	4
GSRs 2010-120			12	50	4
GSRs 2010-160			16	50	4
GSRs 2010-200	1.5	-	20	50	4
GSRs 2015-040			4	50	4
GSRs 2015-060			6	50	4
GSRs 2015-080			8	50	4
GSRs 2015-100			10	50	4
GSRs 2015-120			12	50	4
GSRs 2015-160	2	-	16	50	4
GSRs 2015-200			20	50	4
GSRs 2020-040			4	50	4
GSRs 2020-060			6	50	4
GSRs 2020-080			8	50	4
GSRs 2020-100			10	50	4
GSRs 2020-120	2	-	12	50	4
GSRs 2020-160			16	50	4
GSRs 2020-200			20	50	4

Ürün Kodu	D	R	H	L	d
GSRs 2030-100	3	-	10	60	6
GSRs 2030-120			12	60	6
GSRs 2030-160			16	60	6
GSRs 2030-200			20	60	6
GSRs 2030-250	4	-	25	60	6
GSRs 2040-120			12	60	6
GSRs 2040-160			16	60	6
GSRs 2040-200			20	60	6
GSRs 2040-250			25	60	6

genco  
makina

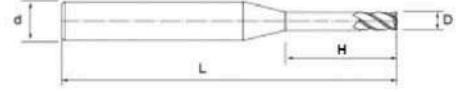

Ürün Kodu	D	R	H	L	d		
GSRs 4010-040	1	-	4	50	4		
GSRs 4010-060			6	50	4		
GSRs 4010-080			8	50	4		
GSRs 4010-100			10	50	4		
GSRs 4010-120			12	50	4		
GSRs 4010-160			16	50	4		
GSRs 4010-200			20	50	4		
GSRs 4015-060			1.5	-	6	50	4
GSRs 4015-080	8	50			4		
GSRs 4015-100	10	50			4		
GSRs 4015-120	12	50			4		
GSRs 4015-160	16	50			4		
GSRs 4015-200	20	50			4		
GSRs 4020-060	2	-			6	50	4
GSRs 4020-080					8	50	4
GSRs 4020-100			10	50	4		
GSRs 4020-120			12	50	4		
GSRs 4020-160			16	50	4		
GSRs 4020-200			20	50	4		

Ürün Kodu	D	R	H	L	d
GSRs 4030-100	3	-	10	60	6
GSRs 4030-120			12	60	6
GSRs 4030-160			16	60	6
GSRs 4030-200			20	60	6
GSRs 4030-250			25	60	6
GSRs 4040-120	4	-	12	60	6
GSRs 4040-160			16	60	6
GSRs 4040-200			20	60	6
GSRs 4040-250			25	60	6





4.5 HRC  
GS-G SERİ

genco  
makina

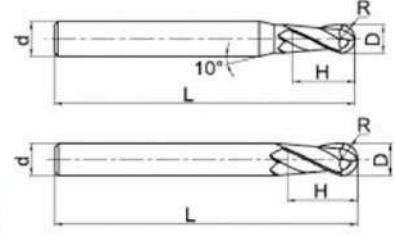
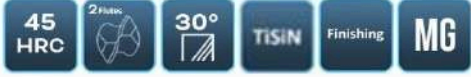

Ürün Kodu	D	R	H	L	d
GSSB 2030	3	1.5	6	50	3
GSSB 2030			6	75	3
GSSB 2040	4	2	8	50	4
GSLB 2040			8	75	4
GSSB 2060	6	3	9	50	6
GSMB 2060			9	75	6
GSLB 2060			9	100	6
GSSB 2080	8	4	12	60	8
GSLB 2080			12	100	8

Ürün Kodu	D	R	H	L	d
GSSB 2100	10	5	15	75	10
GSLB 2100			15	100	10
GSSB 2120	12	6	18	75	12
GSLB 2120			18	100	12

genco  
makina

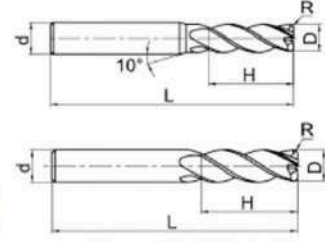
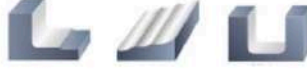

Ürün Kodu	D	R	H	L	d
GSSC 4030R05G	3	0.5	8	60	3
GSLC 4030R05G			8	75	3
GSSC 4040R05G	4	0.5	8	60	4
GSLC 4040R05G			8	75	4
GSSC 4060R05G	6	0.5	12	60	6
GSMC 4060R05G			12	75	6
GSLC 4060R05G			12	100	6
GSSC 4060R10G	6	1	12	60	6
GSMC 4060R10G			12	75	6
GSLC 4060R10G			12	100	6
GSSC 4080R05G	8	0.5	16	60	8
GSLC 4080R05G			16	100	8
GSSC 4080R10G	8	1	16	60	8
GSLC 4080R10G			16	100	8

Ürün Kodu	D	R	H	L	d
GSSC 4100R05G	10	0.5	20	75	10
GSLC 4100R05G			20	100	10
GSSC 4100R10G	10	1	20	75	10
GSLC 4100R10G			20	100	10
GSSC 4120R05G	12	0.5	24	75	12
GSLC 4120R05G			24	100	12
GSSC 4120R10G	12	1	24	75	12
GSLC 4120R10G			24	100	12

genco  
makina

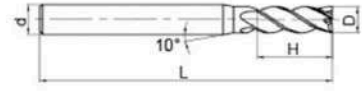
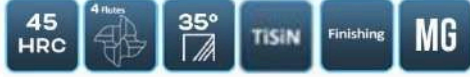

Ürün Kodu	D	R	H	L	d
GSSS 4030G	3	-	8	50	3
GSLs 4030G			8	75	3
GSSS 4040G	4	-	11	50	4
GSLs 4040G			11	75	4
GSSS 4060G	6	-	15	50	6
GSLs 4060G			20	100	6
GSSS 4080G	8	-	20	60	8
GSLs 4080G			25	100	8

Ürün Kodu	D	R	H	L	d
GSSS 4100G	10	-	30	75	10
GSLs 4100G			30	100	10
GSSS 4120G	12	-	30	75	12
GSLs 4120G			35	100	12
GSLs 4160G	16	-	45	100	16



AL  
GA SERİ

genco  
makina

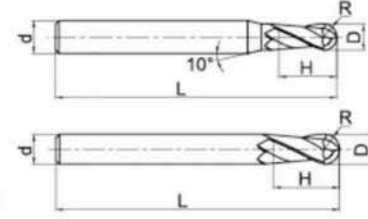

Ürün Kodu	D	R	H	L	d
GASB 2002	0.2	0.1	0.4	50	4
GASB 2003	0.3	0.15	0.6	50	4
GASB 2004	0.4	0.2	0.8	50	4
GASB 2005	0.5	0.25	1	50	4
GASB 2006	0.6	0.3	1	50	4
GASB 2007	0.7	0.35	1	50	4
GASB 2008	0.8	0.4	2	50	4
GASB 2009	0.9	0.45	2	50	4
GASB 2010	1	0.5	2	50	4
GASB 2015	1.5	0.75	3	50	4
GASB 2020	2	1	4	50	4
GASB 2025	2.5	1.25	5	50	4
GASB 2030			6	50	3
GALB 2030			6	75	3
GASB 2030-4	3	1.5	6	50	4
GALB 2030-6			6	50	6
GASB 2030-6			6	75	6
GASB 2040			8	50	4
GALB 2040			8	75	4
GAXB 2040	4	2	8	100	4
GASB 2040-6			8	50	6
GALB 2040-6			8	75	6
GAXB 2040-6			8	100	6
GASB 2050			10	50	5
GALB 2050	5	2.5	10	75	5
GAXB 2050			10	100	5
GASB 2060			12	50	6
GAMB 2060			12	75	6
GALB 2060	6	3	12	100	6
GAXB 2060			12	150	6
GASB 2080			16	60	8
GALB 2080	8	4	16	100	8
GAXB 2080			16	150	8

Ürün Kodu	D	R	H	L	d
GASB 2100			20	75	10
GALB 2100	10	5	20	100	10
GAXB 2100			20	150	10
GASB 2120			24	75	12
GALB 2120	12	6	24	100	12
GAXB 2120			24	150	12

genco  
makina

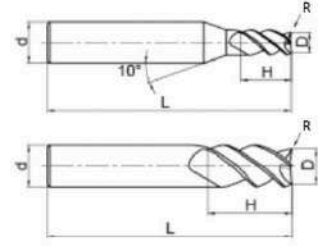

Ürün Kodu	D	R	H	L	d
GASC 3030R05	3	0.5	8	50	3
GALC 3030R05			8	75	3
GASC 3030R05-6			8	75	6
GASC 3040R05	4	0.5	10	50	4
GALC 3040R05			10	75	4
GAXC 3040R05			10	100	4
GALC 3040R05-6			10	75	6
GAXC 3040R05-6			10	100	6
GAMC 3060R05	6	0.5	15	75	6
GALC 3060R05			15	100	6
GAXS 3060R05			15	150	6
GAMC 3060R10	6	1	15	75	6
GALC 3060R10			15	100	6
GAXS 3060R10			15	150	6
GASC 3080R05	8	0.5	15	60	8
GALC 3080R05			20	100	8
GAXS 3080R05			20	150	8
GASC 3080R10	8	1	20	60	8
GALC 3080R10			20	100	8
GAXS 3080R10			20	150	8

Ürün Kodu	D	R	H	L	d
GASC 3100R05	10	0.5	25	75	10
GALC 3100R05			25	100	10
GAXS 3100R05			25	150	10
GASC 3100R10	10	1	25	75	10
GALC 3100R10			25	100	10
GAXS 3100R10			25	150	10
GASC 3100R20	10	2	25	75	10
GALC 3100R20			25	100	10
GAXS 3100R20			25	150	10
GASC 3120R05	12	0.5	25	75	12
GALC 3120R05			30	100	12
GAXS 3120R05			30	150	12
GASC 3120R10	12	1	30	75	12
GALC 3120R10			30	100	12
GAXS 3120R10			30	150	12
GASC 3120R20	12	2	30	75	12
GALC 3120R20			30	100	12
GAXS 3120R20			30	150	12
GALC 3120R10	16	1	40	100	16
GAXS 3120R10			40	150	16
GALC 3120R20			40	100	16
GAXS 3120R20	16	2	40	150	16

genco  
makina

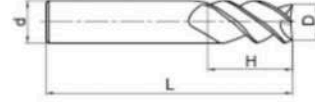
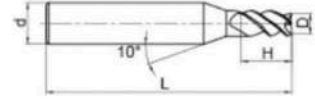

Ürün Kodu	D	CR	H	L	d
GASS 2002	0.2	-	0.4	50	4
GASS 2003	0.3	-	0.6	50	4
GASS 2004	0.4	-	0.8	50	4
GASS 2005	0.5	-	1	50	4
GASS 2006	0.6	-	1	50	4
GASS 2007	0.7	-	1	50	4
GASS 2008	0.8	-	2	50	4
GASS 2009	0.9	-	2	50	4
GASS 3010	1	-	3	50	4
GASS 3015	1.5	-	4	50	4
GASS 3020	2	-	6	50	4
GASS 3025	2.5	-	7	50	4
GASS 3030			8	50	3
GALS 3030			8	75	3
GALS 3030-4	3	-	8	50	4
GASS 3030-6			8	50	6
GALS 3030-6			8	75	6
GASS 3040			12	50	4
GALS 3040			15	75	4
GAXS 3040			20	100	4
GASS 3040-6	4	-	12	50	6
GALS 3040-6			15	75	6
GAXS 3040-6			20	100	6
GASS 3050			15	50	5
GALS 3050	5	-	20	75	5
GAXS 3050			20	100	5
GASS 3060			18	50	6
GAMS 3060			25	75	6
GALS 3060	6	-	30	100	6
GAXS 3060			30	150	6

Ürün Kodu	D	CR	H	L	d
GASS 3080			20	60	8
GALS 3080	8	-	30	100	8
GAXS 3080			35	150	8
GASS 3100			30	75	10
GALS 3100	10	-	35	100	10
GAXS 3100			45	150	10
GASS 3120			30	75	12
GALS 3120	12	-	35	100	12
GAXS 3120			45	150	12
GASS 3160			45	100	16
GALS 3160	16	-	55	150	16



GRAFIT  
GD SERİ

genco  
makina

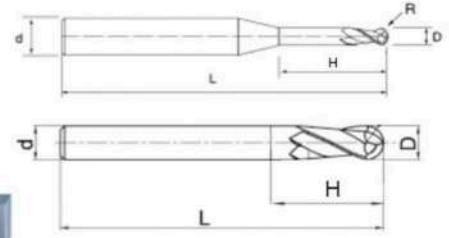

Ürün Kodu	D	R	H	L	d
GDRB 2005-020	0.5	0.25	2	75	4
GDRB 2005-040			4	75	4
GDRB 2005-060			6	75	4
GDRB 2005-080			8	75	4
GDRB 2006-020	0.6	0.3	2	75	4
GDRB 2006-040			4	75	4
GDRB 2006-060			6	75	4
GDRB 2006-080			8	75	4
GDRB 2008-020	0.8	0.4	2	75	4
GDRB 2008-040			4	75	4
GDRB 2008-060			6	75	4
GDRB 2008-080			8	75	4
GDRB 2008-100			10	75	4
GDRB 2008-120			12	75	4
GDRB 2008-160			16	75	4
GDRB 2008-200			20	75	4
GDRB 2010-120	1	0.5	12	75	4
GDRB 2010-160			16	75	4
GDRB 2010-200			20	75	4
GDRB 2010-250			25	75	4
GDRB 2010-300	1.5	0.75	30	75	4
GDRB 2015-120			12	75	4
GDRB 2015-160			16	75	4
GDRB 2015-200			20	75	4
GDRB 2015-250	2	1	25	75	4
GDRB 2015-300			30	75	4
GDRB 2020-120			12	75	4
GDRB 2020-160			16	75	4
GDRB 2020-200	3	1.5	20	75	4
GDRB 2020-250			25	75	4
GDRB 2020-300			30	75	4
GDRB 2020-400			40	75	4
GDRB 2020-500	4	2	50	100	4
GDRB 2030-200			20	100	4
GDRB 2030-300			30	100	4
GDRB 2030-400			40	100	4
GDRB 2030-500	6	3	50	100	4
GDRB 2040-200			20	100	4
GDRB 2040-300			30	150	4
GDRB 2060-200			20	100	6
GDRB 2060-300	8	4	30	150	6
GDRB 2080-200			20	100	8
GDRB 2080-300			30	150	8

Ürün Kodu	D	R	H	L	d
GDRB 2100-200	10	5	20	100	10
GDRB 2100-300			30	150	10
GDRB 2120-200	12	6	20	100	12
GDRB 2120-300			30	150	12

genco  
makina

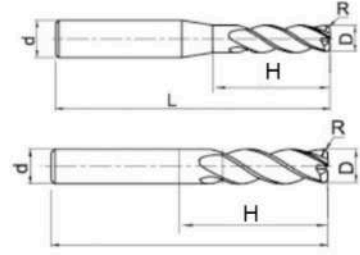

Ürün Kodu	D	R	H	L	d
GDRC 4010-02-120	1	0.2	12	75	4
GDRC 4010-02-160			16	75	4
GDRC 4010-02-200			20	75	4
GDRC 4010-02-250			25	75	4
GDRC 4010-02-300			30	75	4
GDRC 4015-02-120	1.5	0.2	12	75	4
GDRC 4015-02-160			16	75	4
GDRC 4015-02-200			20	75	4
GDRC 4015-02-250			25	75	4
GDRC 4015-02-300			30	75	4
GDRC 4020-02-120	2	0.2	12	75	4
GDRC 4020-02-160			16	75	4
GDRC 4020-02-200			20	75	4
GDRC 4020-02-250			25	75	4
GDRC 4020-02-300			30	75	4
GDRC 4020-02-400			40	100	4
GDRC 4030-05-200	3	0.5	20	100	4
GDRC 4030-05-300			30	100	4
GDRC 4030-05-400			40	100	4
GDRC 4030-05-500			50	100	4
GDRC 4040-05-200	4	0.5	20	100	4
GDRC 4040-05-300			30	150	4
GDRC 4060-05-300	6	0.5	30	100	6
GDRC 4060-05-400			40	150	6
GDRC 4060-10-300	6	1	30	100	6
GDRC 4060-10-400			40	150	6
GDRC 4080-05-400	8	0.5	30	100	8
GDRC 4080-05-500			40	150	8
GDRC 4080-10-400	8	1	30	100	8
GDRC 4080-10-500			40	150	8

Ürün Kodu	D	R	H	L	d
GDRC 4100-05-500	10	0.5	50	100	10
GDRC 4100-05-600			60	150	10
GDRC 4100-10-500	10	1	30	100	10
GDRC 4100-10-600			40	150	10
GDRC 4120-05-500	12	0.5	50	100	12
GDRC 4120-05-600			60	150	12
GDRC 4120-10-500	12	1	30	100	12
GDRC 4120-10-600			40	150	12



30 HRC  
GP SERİ

genco  
makina

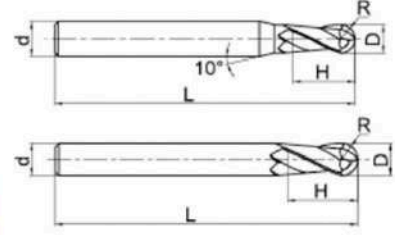
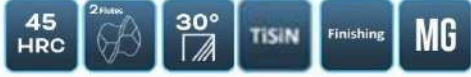

Ürün Kodu	D	R	H	L	d
GPSB 2010	1	0.5	2	50	4
GPSB 2015	1.5	0.75	3	50	4
GPSB 2020	2	1	4	50	4
GPSB 2030			6	50	3
GPLB 2030	3	1.5	6	75	3
GPXB 2030			6	100	3
GPSB 2040			8	50	4
GPLB 2040	4	2	8	75	4
GPXB 2040			8	100	4
GPSB 2050			10	50	6
GPLB 2050	5	2.5	10	100	6
GPXB 2050			10	150	6
GPSB 2060			12	50	6
GPLB 2060	6	3	12	100	6
GPXB 2060			12	150	6
GPSB 2080			16	60	8
GPLB 2080	8	4	16	100	8
GPXB 2080			16	150	8

Ürün Kodu	D	R	H	L	d
GPSB 2100			20	75	10
GPLB 2100	10	5	20	100	10
GPXB 2100			20	150	10
GPSB 2120			24	75	12
GPLB 2120	12	6	24	100	12
GPXB 2120			24	150	12

genco  
makina

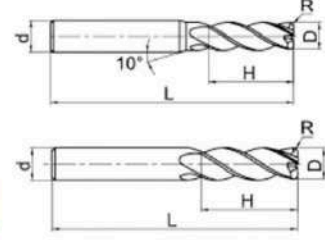
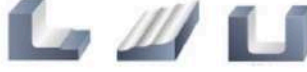

Ürün Kodu	D	R	H	L	d
GPSC 4010R02	1	0.2	3	50	4
GPSC 4015R02	1.5	0.2	4	50	4
GPSC 4020R02	2	0.2	6	50	4
GPSC 4020R05	2	0.5	6	50	4
GPSC 4025R02	2.5	0.2	8	50	4
GPSC 4025R05	2.5	0.5	8	50	4
GPSC 4030R02			8	50	3
GPLC 4030R02	3	0.2	8	75	3
GPXC 4030R02			8	100	3
GPSC 4030R05			8	50	3
GPLC 4030R05	3	0.5	8	75	3
GPXC 4030R05			8	100	3
GPSC 4030R10			8	50	3
GPLC 4030R10	3	1	8	75	3
GPXC 4030R10			8	100	3
GPSC 4040R02			10	50	4
GPLC 4040R02	4	0.2	10	75	4
GPXC 4040R02			10	100	4
GPSC 4040R05			10	50	4
GPLC 4040R05	4	0.5	10	75	4
GPXC 4040R05			10	100	4
GPSC 4040R10			10	50	4
GPLC 4040R10	4	1	10	75	4
GPXC 4040R10			10	100	4
GPSC 4050R05			13	50	5
GPLC 4050R05	5	0.5	13	75	5
GPXC 4050R05			13	100	5
GPSC 4050R10			13	50	5
GPLC 4050R10	5	1	13	75	5
GPXC 4050R10			13	100	5
GPSC 4060R05			15	50	6
GPLC 4060R05	6	0.5	15	100	6
GPXC 4060R05			15	150	6
GPSC 4060R10			15	50	6
GPLC 4060R10	6	1	15	100	6
GPXC 4060R10			15	150	6
GPSC 4080R05			20	60	8
GPLC 4080R05	8	0.5	20	100	8
GPXC 4080R05			20	150	8
GPSC 4080R10			20	60	8
GPLC 4080R10	8	1	20	100	8
GPXC 4080R10			20	150	8

Ürün Kodu	D	R	H	L	d
GPSC 4100R05			25	75	10
GPLC 4100R05	10	0.5	25	100	10
GPXC 4100R05			25	150	10
GPSC 4100R10			25	75	10
GPLC 4100R10	10	1	25	100	10
GPXC 4100R10			25	150	10
GPSC 4120R05			30	75	12
GPLC 4120R05	12	0.5	30	100	12
GPXC 4120R05			30	150	12
GPSC 4120R10			30	75	12
GPLC 4120R10	12	1	30	100	12
GPXC 4120R10			30	150	12

genco  
makina

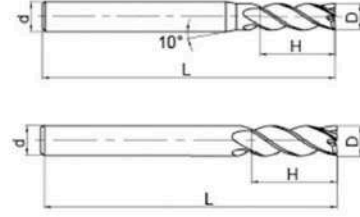

Ürün Kodu	D	R	H	L	d
GPSS 4010	1	-	3	50	4
GPSS 4015	1.5	-	4	50	4
GPSS 4020	2	-	6	50	4
GPSS 4025	2.5	-	8	50	4
GPSS 4030	3	-	8	50	3
GPLS 4030			12	75	3
GPXS 4030			15	100	3
GPSS 4030-4	3.5	-	8	50	4
GPSS 4030-6			8	50	6
GPSS 4035-4			10	50	4
GPSS 4035-6	4	-	10	50	6
GPSS 4040			10	50	4
GPLS 4040			15	75	4
GPXS 4040	4.5	-	20	100	4
GPSS 4040-6			10	50	6
GPSS 4045			13	50	6
GPSS 4050	5	-	13	50	5
GPLS 4050			20	75	5
GPXS 4050			25	100	5
GPSS 4050-6	5.5	-	15	50	6
GPSS 4055			15	50	6
GPSS 4060			15	50	6
GPLS 4060	6	-	30	100	6
GPXS 4060			50	150	6
GPSS 4070			7	-	20
GPSS 4080	8	-	20	50	8
GPLS 4080			35	100	8
GPXS 4080			55	150	8
GPSS 4090	9	-	30	75	10
GPSS 4100	10	-	30	75	10
GPLS 4100			40	100	10
GPXS 4100			60	150	10
GPSS 4110	11	-	35	75	12
GPSS 4120	12	-	35	75	12
GPLS 4120			45	100	12
GPXS 4120			60	150	12

Ürün Kodu	D	R	H	L	d
GPSS 4130	13	-	40	100	14
GPSS 4140	14	-	40	100	14
GPLS 4140			60	150	14
GPSS 4150	15	-	45	100	16
GPSS 4160	16	-	45	100	16
GPLS 4160			70	150	16
GPSS 4170	17	-	45	100	18
GPSS 4180	18	-	45	100	18
GPLS 4180			70	150	18
GPSS 4200	20	-	45	100	20
GPLS 4200			70	150	20

genco  
makina

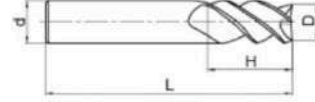
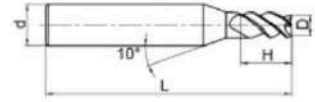

Ürün Kodu	D	CR	H	L	d
GNSS 3010	1	-	3	50	4
GNSS 3015	1.5	-	4	50	4
GNSS 3020	2	-	6	50	4
GNSS 3025	2.5	-	7	50	4
GNSS 3030			8	50	3
GNLS 3030	3	-	12	75	3
GNXS 3030			15	100	3
GNSS 3040			12	50	4
GNLS 3040	4	-	15	75	4
GNXS 3040			20	100	4
GNSS 3050			15	50	5
GNLS 3050	5	-	20	75	5
GNXS 3050			20	100	5
GNSS 3060			18	50	6
GNMS 3060	6	-	25	75	6
GNLS 3060			30	100	6
GNXS 3060			45	150	6

Ürün Kodu	D	CR	H	L	d
GNSS 3080			20	60	8
GNMS 3080	8	-	30	75	8
GNLS 3080			40	100	8
GNXS 3080			50	150	8
GNSS 3100			30	75	10
GNLS 3100	10	-	40	100	10
GNXS 3100			55	150	10
GNSS 3120			35	75	12
GNLS 3120	12	-	45	100	12
GNXS 3120			60	150	12
GNSS 3140			45	100	14
GNLS 3140	14	-	65	150	14
GNSS 3160			45	100	16
GNLS 3160	16	-	65	150	16
GNSS 3200			45	100	20
GNLS 3200	20	-	70	150	20

genco  
makina

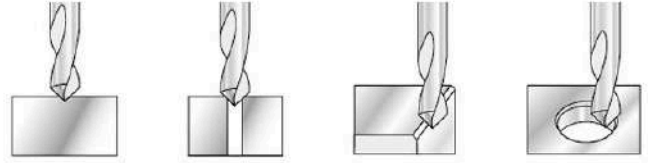

Ürün Kodu	D	$\theta$	L1	L	d
GPSP 2030	3	45	1.5	50	3
GPSP 2040	4	45	2	50	4
GPSP 2050	5	45	2.5	50	5
GPSP 2060	6	45	3	50	6
GPSP 2080	8	45	4	60	8

Ürün Kodu	D	$\theta$	L1	L	d
GPSP 2100	10	45	5	75	10
GPSP 4120	12	45	6	75	12

# Kılavuz

- Kaplamasız
- OX
- TiN





Ürün Kodu	M	DIN	TİP	KAPLAMA	MALZEME
GTNS-M2	M2x0.4	371/376	DÜZ	-	HSS-E
GTNS-M2.5	M2.5x0.45	371/376	DÜZ	-	HSS-E
GTNS-M3	M3x0.5	371/376	DÜZ	-	HSS-E
GTNS-M4	M4x0.7	371/376	DÜZ	-	HSS-E
GTNS-M5	M5x0.8	371/376	DÜZ	-	HSS-E
GTNS-M6	M6x1	371/376	DÜZ	-	HSS-E
GTNS-M8	M8x1.25	371/376	DÜZ	-	HSS-E
GTNS-M10	M10x1.5	371/376	DÜZ	-	HSS-E
GTNS-M12	M12x1.75	371/376	DÜZ	-	HSS-E
GTNS-M14	M14x2	371/376	DÜZ	-	HSS-E
GTNS-M16	M16x2	371/376	DÜZ	-	HSS-E
GTNS-M18	M18x2.5	371/376	DÜZ	-	HSS-E
GTNS-M20	M20x2.5	371/376	DÜZ	-	HSS-E
GTNS-M24	M24x3	371/376	DÜZ	-	HSS-E
GTNS-M30	M30x3	371/376	DÜZ	-	HSS-E
GTNH-M2	M2x0.4	371/376	HELİS	-	HSS-E
GTNH-M2.5	M2.5x0.45	371/376	HELİS	-	HSS-E
GTNH-M3	M3x0.5	371/376	HELİS	-	HSS-E
GTNH-M4	M4x0.7	371/376	HELİS	-	HSS-E
GTNH-M5	M5x0.8	371/376	HELİS	-	HSS-E
GTNH-M6	M6x1	371/376	HELİS	-	HSS-E
GTNH-M8	M8x1.25	371/376	HELİS	-	HSS-E
GTNH-M10	M10x1.5	371/376	HELİS	-	HSS-E
GTNH-M12	M12x1.75	371/376	HELİS	-	HSS-E
GTNH-M14	M14x2	371/376	HELİS	-	HSS-E
GTNH-M16	M16x2	371/376	HELİS	-	HSS-E
GTNH-M18	M18x2.5	371/376	HELİS	-	HSS-E
GTNH-M20	M20x2.5	371/376	HELİS	-	HSS-E
GTNH-M24	M24x3	371/376	HELİS	-	HSS-E
GTNH-M30	M30x3	371/376	HELİS	-	HSS-E



Ürün Kodu	M	DIN	TİP	KAPLAMA	MALZEME
GTOS-M2	M2x0.4	371/376	DÜZ	OXIDE	HSS-E
GTOS-M2.5	M2.5x0.45	371/376	DÜZ	OXIDE	HSS-E
GTOS-M3	M3x0.5	371/376	DÜZ	OXIDE	HSS-E
GTOS-M4	M4x0.7	371/376	DÜZ	OXIDE	HSS-E
GTOS-M5	M5x0.8	371/376	DÜZ	OXIDE	HSS-E
GTOS-M6	M6x1	371/376	DÜZ	OXIDE	HSS-E
GTOS-M8	M8x1.25	371/376	DÜZ	OXIDE	HSS-E
GTOS-M10	M10x1.5	371/376	DÜZ	OXIDE	HSS-E
GTOS-M12	M12x1.75	371/376	DÜZ	OXIDE	HSS-E
GTOS-M14	M14x2	371/376	DÜZ	OXIDE	HSS-E
GTOS-M16	M16x2	371/376	DÜZ	OXIDE	HSS-E
GTOS-M18	M18x2.5	371/376	DÜZ	OXIDE	HSS-E
GTOS-M20	M20x2.5	371/376	DÜZ	OXIDE	HSS-E
GTOS-M24	M24x3	371/376	DÜZ	OXIDE	HSS-E
GTOS-M30	M30x3	371/376	DÜZ	OXIDE	HSS-E
GTOH-M2	M2x0.4	371/376	HELİS	OXIDE	HSS-E
GTOH-M2.5	M2.5x0.45	371/376	HELİS	OXIDE	HSS-E
GTOH-M3	M3x0.5	371/376	HELİS	OXIDE	HSS-E
GTOH-M4	M4x0.7	371/376	HELİS	OXIDE	HSS-E
GTOH-M5	M5x0.8	371/376	HELİS	OXIDE	HSS-E
GTOH-M6	M6x1	371/376	HELİS	OXIDE	HSS-E
GTOH-M8	M8x1.25	371/376	HELİS	OXIDE	HSS-E
GTOH-M10	M10x1.5	371/376	HELİS	OXIDE	HSS-E
GTOH-M12	M12x1.75	371/376	HELİS	OXIDE	HSS-E
GTOH-M14	M14x2	371/376	HELİS	OXIDE	HSS-E
GTOH-M16	M16x2	371/376	HELİS	OXIDE	HSS-E
GTOH-M18	M18x2.5	371/376	HELİS	OXIDE	HSS-E
GTOH-M20	M20x2.5	371/376	HELİS	OXIDE	HSS-E
GTOH-M24	M24x3	371/376	HELİS	OXIDE	HSS-E
GTOH-M30	M30x3	371/376	HELİS	OXIDE	HSS-E



Ürün Kodu	M	DIN	TİP	KAPLAMA	MALZEME
GTTS-M2	M2x0.4	371/376	DÜZ	TiN	HSS-E
GTTS-M2.5	M2.5x0.45	371/376	DÜZ	TiN	HSS-E
GTTS-M3	M3x0.5	371/376	DÜZ	TiN	HSS-E
GTTS-M4	M4x0.7	371/376	DÜZ	TiN	HSS-E
GTTS-M5	M5x0.8	371/376	DÜZ	TiN	HSS-E
GTTS-M6	M6x1	371/376	DÜZ	TiN	HSS-E
GTTS-M8	M8x1.25	371/376	DÜZ	TiN	HSS-E
GTTS-M10	M10x1.5	371/376	DÜZ	TiN	HSS-E
GTTS-M12	M12x1.75	371/376	DÜZ	TiN	HSS-E
GTTS-M14	M14x2	371/376	DÜZ	TiN	HSS-E
GTTS-M16	M16x2	371/376	DÜZ	TiN	HSS-E
GTTS-M18	M18x2.5	371/376	DÜZ	TiN	HSS-E
GTTS-M20	M20x2.5	371/376	DÜZ	TiN	HSS-E
GTTS-M24	M24x3	371/376	DÜZ	TiN	HSS-E
GTTS-M30	M30x3	371/376	DÜZ	TiN	HSS-E
GTTH-M2	M2x0.4	371/376	HELİS	TiN	HSS-E
GTTH-M2.5	M2.5x0.45	371/376	HELİS	TiN	HSS-E
GTTH-M3	M3x0.5	371/376	HELİS	TiN	HSS-E
GTTH-M4	M4x0.7	371/376	HELİS	TiN	HSS-E
GTTH-M5	M5x0.8	371/376	HELİS	TiN	HSS-E
GTTH-M6	M6x1	371/376	HELİS	TiN	HSS-E
GTTH-M8	M8x1.25	371/376	HELİS	TiN	HSS-E
GTTH-M10	M10x1.5	371/376	HELİS	TiN	HSS-E
GTTH-M12	M12x1.75	371/376	HELİS	TiN	HSS-E
GTTH-M14	M14x2	371/376	HELİS	TiN	HSS-E
GTTH-M16	M16x2	371/376	HELİS	TiN	HSS-E
GTTH-M18	M18x2.5	371/376	HELİS	TiN	HSS-E
GTTH-M20	M20x2.5	371/376	HELİS	TiN	HSS-E
GTTH-M24	M24x3	371/376	HELİS	TiN	HSS-E
GTTH-M30	M30x3	371/376	HELİS	TiN	HSS-E



# Takma Uç

- Frezeleme
- Delik İşleme
- Tornalama

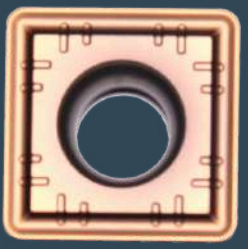
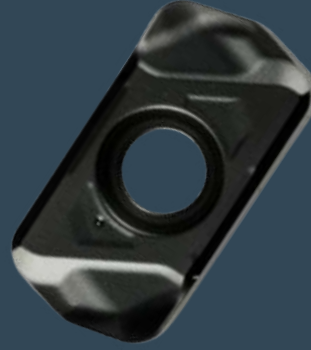
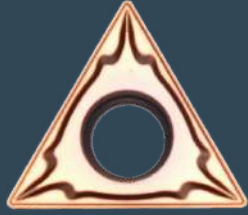
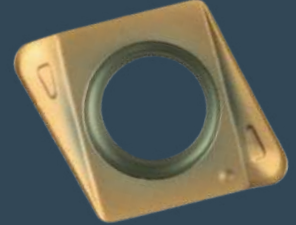
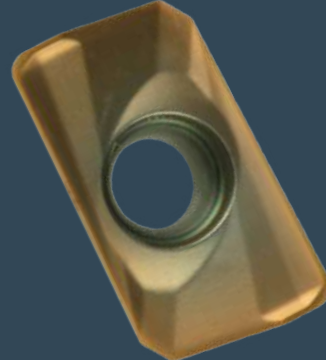
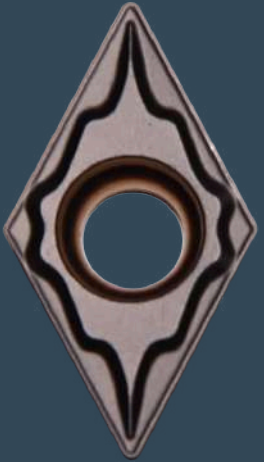
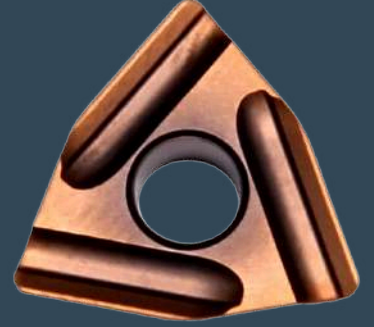

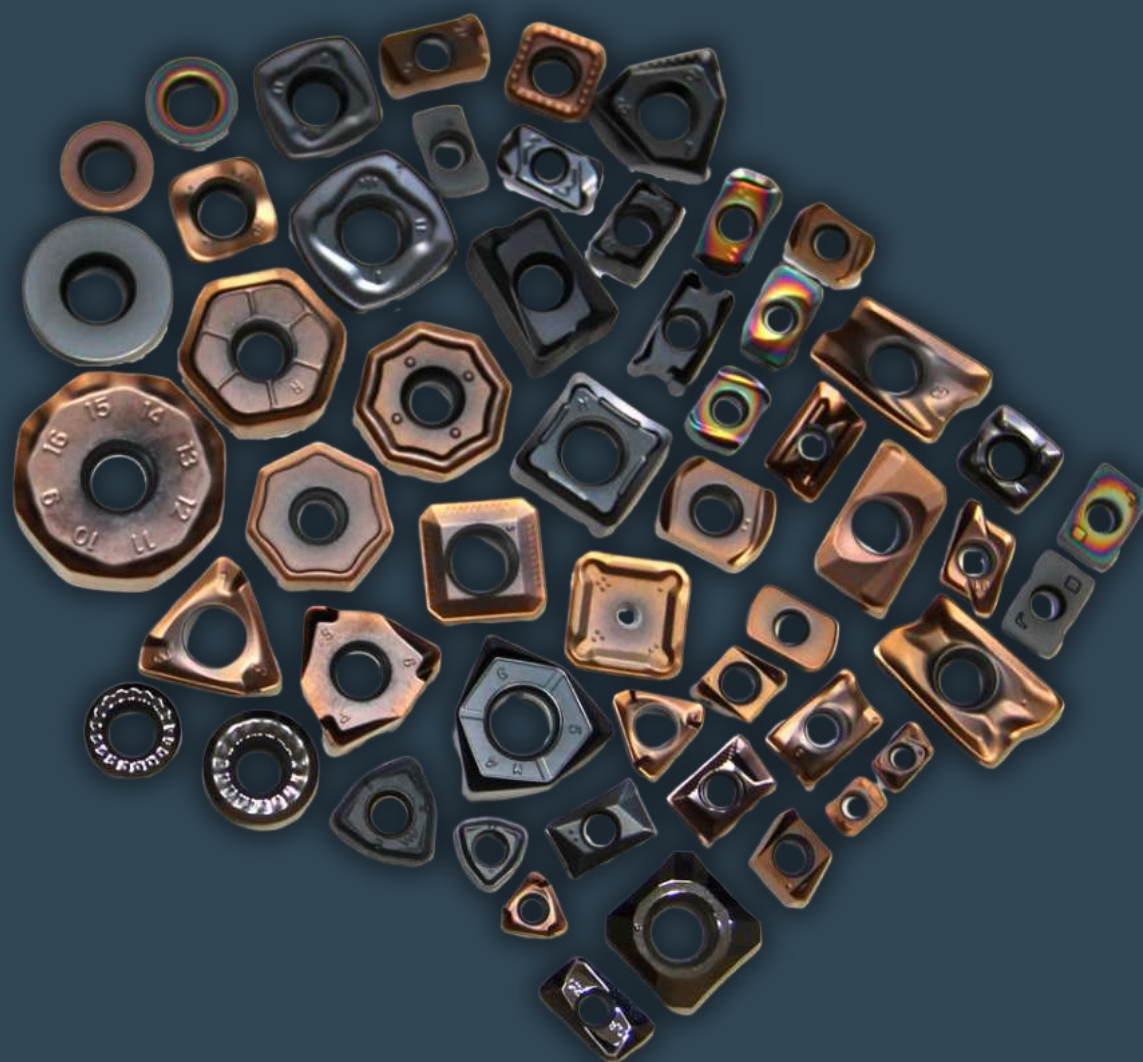

# FREZELEME



Ürün Kodu	R	Açıklama	Uyum
BXMX 0603R-M GF5577	2	Genel Kullanım	BL06
BXMX 0603R-M GF5777	2	Alaşımlı Çelik	BL06
BXMX 0603R-M GF6077	2	Alaşımlı Çelik	BL06
BXHS06 G80	2	Sert Malzeme	BL06
BXD 0603R-M GF6580	2	Aluminyum	BL06
PGBL06-M PRP501	2	Promosyon Seri	BL06
BXMX 0904R-M GF5577	2.5	Genel Kullanım	BL09
BXMX 0904R-M GF5777	2.5	Alaşımlı Çelik	BL09
BXMX 0904R-M GF6077	2.5	Alaşımlı Çelik	BL09
BXHS09 G80	2.5	Alaşımlı Çelik	BL09
GWNX 060312 GF5577	1.2	Genel Kullanım	WNMX06
GWNX 09T316 GF5577	1.6	Genel Kullanım	WNMX09
NLNM 0303ZER-MJ GF5577	2	Genel Kullanım	LNMU
NLNM 0303ZER-MJ GF5777	2	Alaşımlı Çelik	LNMU
NLNM 0303ZER-MJ GF6077	2	Alaşımlı Çelik	LNMU
NLHS 03 G80	2	Sert Malzeme	LNMU
PGLN03-MJ PRP501	2	Promosyon Seri	LNMU
GLGX 030310ER GF5577	2	Genel Kullanım	LOG
GLGX 030310ER GF5777	2	Alaşımlı Çelik	LOG
GLGX 030310ER GF6077	2	Alaşımlı Çelik	LOG
LGHS03 G80	2	Sert Malzeme	LOG
GLT 010210 GF5577	1	Genel Kullanım	LPG10
GLT 010210 GF5777	1	Alaşımlı Çelik	LPG10
GLT 010210 GF6077	1	Alaşımlı Çelik	LPG10
GLHS01 G80	1	Sert Malzeme	LPG10
GDRM 0501 GF5777	2.5	Alaşımlı Çelik	RDMW05
GDRM 0501 GF6077	2.5	Alaşımlı Çelik	RDMW05
GDRM 0702 GF5777	3.5	Alaşımlı Çelik	RDMW07
GDRM 0702 GF6077	3.5	Alaşımlı Çelik	RDMW07
GDRM 0803 GF5777	4	Alaşımlı Çelik	RDMW08
GDRM 0803 GF6077	4	Alaşımlı Çelik	RDMW08
GDRH 1003 GF5777	5	Alaşımlı Çelik	RDHW10
GRHS10 G80	5	Sert Malzeme	RDHW10
GDRM 1003 GF5777	5	Alaşımlı Çelik	RDMW10
GDRM 1003 GF6077	5	Alaşımlı Çelik	RDMW10
GKT 1204MO GF5777	6	Alaşımlı Çelik	RDKT12
GKT 1204MO GF6077	6	Alaşımlı Çelik	RDKT12
GRDK 12T3MO GF5577	6	Genel Kullanım	RDKW12
GRDK 1604 GF5577	8	Genel Kullanım	RDKW16



Ürün Kodu	R	Açıklama	Uyum
GSMT 1004 GF5577	2	Genel Kullanım	SOMT
GSMT 1004 GF5777	2	Alaşımlı Çelik	SOMT
SDGX 09T307-KM GF5577	2	Genel Kullanım	SDMT09
SDGX 09T307-KM GF5777	2	Alaşımlı Çelik	SDMT09
SDGX 09T320 GF5777	2	Alaşımlı Çelik	SDMT09
SDGX 09T320 GF6077	2	Alaşımlı Çelik	SDMT09
SDGX 120512-JW GF5577	2	Genel Kullanım	SDMT12
SDGX 150512-JW GF5577	2	Genel Kullanım	SDMT15
BXNM 1004 GF5577	2	Genel Kullanım	ENMU
BXNM 1004 GF5777	2	Alaşımlı Çelik	ENMU
GPW 0603TN GF5577	2	Genel Kullanım	EPNW06
GPW 0603TN GF5777	2	Alaşımlı Çelik	EPNW06
GPW 0603TN GF6077	2	Alaşımlı Çelik	EPNW06
GRCX 0803MO NC25	4	Aluminyum	RCGT08
GRCX 10T3MO NC25	5	Aluminyum	RCGT10
GRCX 1204MO NC25	6	Aluminyum	RCGT12
GRCX 1606MO NC25	8	Aluminyum	RCGT16



Ürün Kodu	R	Açıklama	Uyum
APMX 1135PDER-H2 GF5577	0.8	Genel Kullanım	APMT11
APMX 1135PDER-H2 GF5777	0.8	Alaşımlı Çelik	APMT11
APMX 1135PDER-H2 GF6077	0.8	Alaşımlı Çelik	APMT11
APMX 1135PDER-H2 GF5877	0.8	Sert Malzeme	APMT11
AXHS11-G80	0.8	Sert Malzeme	APMT11
PGAP11-H2 PRP501	0.8	Promosyon Seri	APMT11
APXN 160408PDER-H2 GF5577	0.8	Genel Kullanım	APMT16
APXN 160408PDER-H2 GF5777	0.8	Alaşımlı Çelik	APMT16
APXN 160408PDER-H2 GF6077	0.8	Alaşımlı Çelik	APMT16
GPAX 09T3R GF5577	0.8	Genel Kullanım	APKT09
GPAX 09T3R GF5777	0.8	Alaşımlı Çelik	APKT09
GPAX 100305 GF5577	0.5	Genel Kullanım	APKT10
GPAX 100305 GF5777	0.5	Alaşımlı Çelik	APKT10
GPAX 100305 GF6077	0.5	Alaşımlı Çelik	APKT10
GPHS 1005 G80	0.5	Sert Malzeme	APKT10
GPAX 100308 GF5577	0.8	Genel Kullanım	APKT10
GPAX 100308 GF5777	0.8	Alaşımlı Çelik	APKT10
GPAX 100308 GF6077	0.8	Alaşımlı Çelik	APKT10
GPHS 1008 G80	0.5	Sert Malzeme	APKT10
GPAX 100305 NC25	0.5	Aluminyum	APKT10
GPAX 100308 NC25	0.8	Aluminyum	APKT10
GPAX 160405 NC25	0.5	Aluminyum	APKT16
GPAX 160408 NC25	0.8	Aluminyum	APKT16
GPAX 170508PDER-GF5777	0.8	Alaşımlı Çelik	APKT17
GPAX 170508PDER-GF6077	0.8	Alaşımlı Çelik	APKT17
AXG 123504PEER-G GF5777	0.4	Alaşımlı Çelik	AXMT12
AXG 123504PEER-G GF6077	0.4	Alaşımlı Çelik	AXMT12
AXG 170508PEER-G GF5777	0.8	Alaşımlı Çelik	AXMT17
AXG 170508PEER-G GF6077	0.8	Alaşımlı Çelik	AXMT17
GXR 1003 GF5777	0.8	Alaşımlı Çelik	RT10
ADB 11T308ER-JT-GF5577	0.8	Genel Kullanım	BDM.
ADB 11T308ER-JT-GF5777	0.8	Alaşımlı Çelik	BDM.
JXMX 070204 GF5777	0.4	Alaşımlı Çelik	JDMT07
JXMX 070204 GF6077	0.4	Alaşımlı Çelik	JDMT07
JXMX 070204 GF5877	0.4	Sert Malzeme	JDMT07
JXHS04 G80	0.4	Sert Malzeme	JDMT07
JXMX 070208 GF5777	0.8	Alaşımlı Çelik	JDMT07
JXMX 070208 GF6077	0.8	Alaşımlı Çelik	JDMT07
JXMX 070208 GF5877	0.8	Sert Malzeme	JDMT07
JXHS08 G80	0.8	Sert Malzeme	JDMT07
JXAD 070204 GF6580	0.4	Aluminyum	JDMT07
JXAD 070208 GF6580	0.8	Aluminyum	JDMT07
G3X 060308R GF5777	0.8	Alaşımlı Çelik	3PK.
G3X 100408R GF5777	0.8	Alaşımlı Çelik	3PK.
G3X 150508R GF5777	0.8	Alaşımlı Çelik	3PK.
G4X 060308R-M GF5777	0.8	Alaşımlı Çelik	4NK.
G4HS06 G80	0.8	Sert Malzeme	4NK.
PGNK06-M PRP501	0.8	Promosyon Seri	4NK.



Ürün Kodu	R	Açıklama	Uyum
GPH 060308 GF5877	0.8	Sert Malzeme	MPHW06
GWH 100308 GF5877	0.8	Sert Malzeme	YPHW10
GN6 060408R GF5777	0.8	Alaşımlı Çelik	6NGU06
GN6 060408R GF5882	0.8	Sert Malzeme	6NGU06
GN6 090508R GF5777	0.8	Alaşımlı Çelik	6NGU09
GN6 090508R GF5882	0.8	Sert Malzeme	6NGU09
GWN 080608-GM GF5577	0.8	Genel Kullanım	WNMU
GWN 080608-GM GF5777	0.8	Alaşımlı Çelik	WNMU
GXNX 080608TR-M13 GF5577	0.8	Genel Kullanım	XNEX08
GXNX 080608TR-M13 GF5777	0.8	Alaşımlı Çelik	XNEX08
GLNP 110408SRGE GF5577	0.8	Genel Kullanım	LNPU11
GLNP 110408SRGE GF5777	0.8	Alaşımlı Çelik	LNPU11



Ürün Kodu	R	Açıklama	Uyum
GSNX1205ANN-M GF5577		Genel Kullanım	SNMX12
GNGH 0907AN GF5777		Alaşımlı Çelik	HNMG09
GWN 080608-GM GF5577		Genel Kullanım	WNMU
GWN 080608-GM GF5777		Alaşımlı Çelik	WNMU
GEMT 1204AFTN-M GF5577		Genel Kullanım	SEMT12
GEMT 1204AFTN-M GF5777		Alaşımlı Çelik	SEMT12
GSER 1203-AFS GF5577		Genel Kullanım	SEER12
GSER 1203-AFS GF5777		Alaşımlı Çelik	SEER12
GSET SEET 1203 GF5577		Genel Kullanım	SEET12
GSET SEET 1203 GF5777		Alaşımlı Çelik	SEET12
GSKR 1203AZ-YM GF5577		Genel Kullanım	SEKR12
GSKR 1203AZ-YM GF5777		Alaşımlı Çelik	SEKR12
GSPK 120408 GF5577		Genel Kullanım	SPKN12
GSPK 150430 GF5577		Genel Kullanım	SPKN15
GSPK 190460 GF5577		Genel Kullanım	SPKN19
GXNM 070508-F57 GF5577		Genel Kullanım	XNMU07
GHNU 050408-AR GF5777		Alaşımlı Çelik	ONHU05
GSHT 1204 NC25		Aluminyum	SEHT12

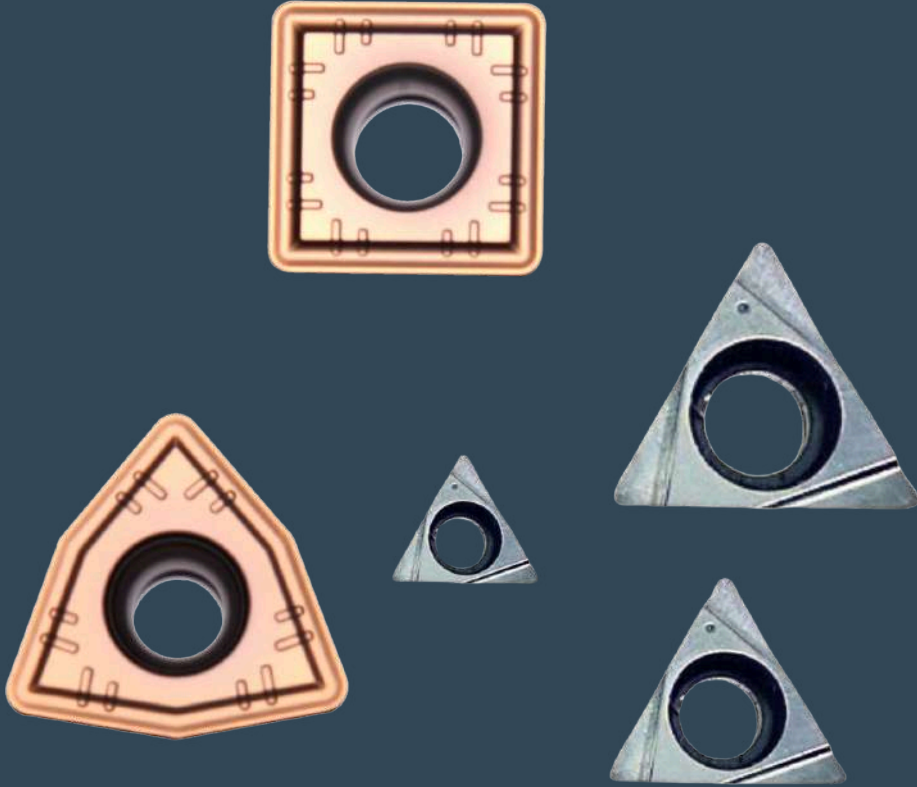

# DELİK İŞLEME



Ürün Kodu	R	P	M	K	N
WCMX 030208-JW GF5777	0.8	•	•	•	
WCMX 040208-JW GF5777	0.8	•	•	•	
WCMX 050308-JW GF5777	0.8	•	•	•	
WCMX 06T308-JW GF5777	0.8	•	•	•	
WCMX 080412-JW GF5777	1.2	•	•	•	
WCMX 030208-JW GF6077	0.8	•	•	•	
WCMX 040208-JW GF6077	0.8	•	•	•	
WCMX 050308-JW GF6077	0.8	•	•	•	
WCMX 06T308-JW GF6077	0.8	•	•	•	
WCMX 080412-JW GF6077	1.2	•	•	•	
SPMG 050204-JW GF5777	0.4	•	•	•	
SPMG 060204-JW GF5777	0.4	•	•	•	
SPMG 07G308-JW GF5777	0.8	•	•	•	
SPMG 090408-JW GF5777	0.8	•	•	•	
SPMG 110408-JW GF5777	0.8	•	•	•	
SPMG 140512-JW GF5777	1.2	•	•	•	
SPMG 050204-JW GF6077	0.4	•	•	•	
SPMG 060204-JW GF6077	0.4	•	•	•	
SPMG 07G308-JW GF6077	0.8	•	•	•	
SPMG 090408-JW GF6077	0.8	•	•	•	
SPMG 110408-JW GF6077	0.8	•	•	•	
SPMG 140512-JW GF6077	1.2	•	•	•	
SOMT 050204DP-GF5777	0.4	•	•	•	
SOMT 060204DP-GF5777	0.4	•	•	•	
SOMT 070308DP-GF5777	0.8	•	•	•	
SOMT 08T306DP-GF5777	0.8	•	•	•	
SOMT 09T308DP-GF5777	0.8	•	•	•	
SOMT 11T308DP-GF5777	0.8	•	•	•	
SOMT 130408DP-GF5777	0.8	•	•	•	
SOMT 150510DP-GF5777	1.0	•	•	•	
SOMT 050204DP-GF6077	0.4	•	•	•	
SOMT 060204DP-GF6077	0.4	•	•	•	
SOMT 070308DP-GF6077	0.8	•	•	•	
SOMT 08T306DP-GF6077	0.8	•	•	•	
SOMT 09T308DP-GF6077	0.8	•	•	•	
SOMT 11T308DP-GF6077	0.8	•	•	•	
SOMT 130408DP-GF6077	0.8	•	•	•	
SOMT 150510DP-GF6077	1.0	•	•	•	
WCKT 030208-NC501	0.8				•
WCKT 040208-NC501	0.8				•
WCKT 050308-NC501	0.8				•
WCKT 06T308-NC501	0.8				•
WCKT 080412-NC501	1.2				•

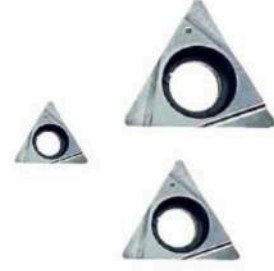

Ürün Kodu	R	Açıklama	Uyum
GXTH 060102 NC35	0.2	Genel Kullanım	TPGH06
GXTH 060104 NC35	0.4	Genel Kullanım	TPGH06
GXTH 080202 NC35	0.2	Genel Kullanım	TPGH08
GXTH 080204 NC35	0.4	Genel Kullanım	TPGH08
GXTH 090202 NC35	0.2	Genel Kullanım	TPGH09
GXTH 090204 NC35	0.4	Genel Kullanım	TPGH09
GXTH 110302 NC35	0.2	Genel Kullanım	TPGH11
GXTH 110304 NC35	0.4	Genel Kullanım	TPGH11

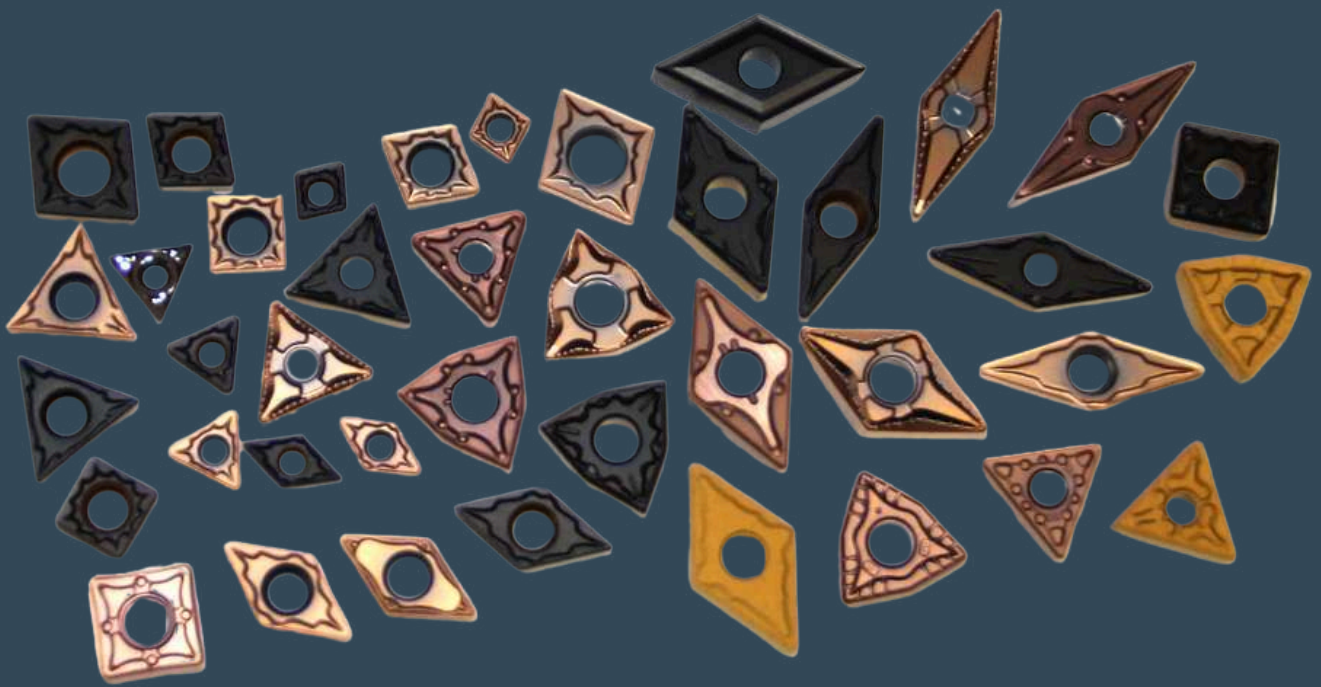

# TORNALAMA



Ürün Kodu	R	P	M	K	N
WNMG 060404-AM GK3867	0.4	•			
WNMG 060408-AM GK3867	0.8	•			
WNMG 060412-AM GK3867	1.2	•			
WNMG 080404-AM GK3867	0.4	•			
WNMG 080408-AM GK3867	0.8	•			
WNMG 080412-AM GK3867	1.2	•			
WNMG 060404-AM GK3877	0.4	•			
WNMG 060408-AM GK3877	0.8	•			
WNMG 060412-AM GK3877	1.2	•			
WNMG 080404-AM GK3877	0.4	•			
WNMG 080408-AM GK3877	0.8	•			
WNMG 080412-AM GK3877	1.2	•			
WNMG 060404-TM GK3867	0.4	•			
WNMG 060408-TM GK3867	0.8	•			
WNMG 060412-TM GK3867	1.2	•			
WNMG 080404-TM GK3867	0.4	•			
WNMG 080408-TM GK3867	0.8	•			
WNMG 080412-TM GK3867	1.2	•			
WNMG 060404-TM GK3877	0.4	•			
WNMG 060408-TM GK3877	0.8	•			
WNMG 060412-TM GK3877	1.2	•			
WNMG 080404-TM GK3877	0.4	•			
WNMG 080408-TM GK3877	0.8	•			
WNMG 080412-TM GK3877	1.2	•			
WNMG 060404-GM GK3867	0.4	•			
WNMG 060408-GM GK3867	0.8	•			
WNMG 060412-GM GK3867	1.2	•			
WNMG 080404-GM GK3867	0.4	•			
WNMG 080408-GM GK3867	0.8	•			
WNMG 080412-GM GK3867	1.2	•			
WNMG 060404-GM GK3877	0.4	•			
WNMG 060408-GM GK3877	0.8	•			
WNMG 060412-GM GK3877	1.2	•			
WNMG 080404-GM GK3877	0.4	•			
WNMG 080408-GM GK3877	0.8	•			
WNMG 080412-GM GK3877	1.2	•			
WNMG 080408L-S GK3867	0.8	•			
WNMG 080408R-S GK3867	0.8	•			
WNMG 080408L-S GK3877	0.8	•			
WNMG 080408R-S GK3877	0.8	•			



Ürün Kodu	R	P	M	K	N
WNMG 060404-MA GF5777	0.4		•		
WNMG 060408-MA GF5777	0.8		•		
WNMG 060412-MA GF5777	1.2		•		
WNMG 080404-MA GF5777	0.4		•		
WNMG 080408-MA GF5777	0.8		•		
WNMG 080412-MA GF5777	1.2		•		
WNMG 060404-MA GF6077	0.4		•		
WNMG 060408-MA GF6077	0.8		•		
WNMG 060412-MA GF6077	1.2		•		
WNMG 080404-MA GF6077	0.4		•		
WNMG 080408-MA GF6077	0.8		•		
WNMG 080412-MA GF6077	1.2		•		
WNMG 060404-BM GF5777	0.4		•		
WNMG 060408-BM GF5777	0.8		•		
WNMG 060412-BM GF5777	1.2		•		
WNMG 080404-BM GF5777	0.4		•		
WNMG 080408-BM GF5777	0.8		•		
WNMG 080412-BM GF5777	1.2		•		
WNMG 060404-BM GF6077	0.4		•		
WNMG 060408-BM GF6077	0.8		•		
WNMG 060412-BM GF6077	1.2		•		
WNMG 080404-BM GF6077	0.4		•		
WNMG 080408-BM GF6077	0.8		•		
WNMG 080412-BM GF6077	1.2		•		
WNMG 080404-WMF GF5777	0.4		•		
WNMG 080408-WMF GF5777	0.8		•		
WNMG 080404-WMF GF6077	0.4		•		
WNMG 080408-WMF GF6077	0.8		•		
WNMG 080408L-S GF5777	0.8		•		
WNMG 080408R-S GF5777	0.8		•		
WNMG 080408L-S GF6077	0.8		•		
WNMG 080408R-S GF6077	0.8		•		
WNMG 060404-CM GK4767	0.4			•	
WNMG 060408-CM GK4767	0.8			•	
WNMG 060412-CM GK4767	1.2			•	
WNMG 080404-CM GK4767	0.4			•	
WNMG 080408-CM GK4767	0.8			•	
WNMG 080412-CM GK4767	1.2			•	
WNMG 080404 NC25	0.4				•
WNMG 080408 NC25	0.8				•
WNMG 080412 NC25	1.2				•



Ürün Kodu	R	P	M	K	N
DNMG 110404-AM GK3867	0.4	•			
DNMG 110408-AM GK3867	0.8	•			
DNMG 110412-AM GK3867	1.2	•			
DNMG 150404-AM GK3867	0.4	•			
DNMG 150408-AM GK3867	0.8	•			
DNMG 150412-AM GK3867	1.2	•			
DNMG 150604-AM GK3867	0.4	•			
DNMG 150608-AM GK3867	0.8	•			
DNMG 150612-AM GK3867	1.2	•			
DNMG 110404-AM GK3877	0.4	•			
DNMG 110408-AM GK3877	0.8	•			
DNMG 110412-AM GK3877	1.2	•			
DNMG 150404-AM GK3877	0.4	•			
DNMG 150408-AM GK3877	0.8	•			
DNMG 150412-AM GK3877	1.2	•			
DNMG 150604-AM GK3877	0.4	•			
DNMG 150608-AM GK3877	0.8	•			
DNMG 150612-AM GK3877	1.2	•			
DNMG 110404-TM GK3867	0.4	•			
DNMG 110408-TM GK3867	0.8	•			
DNMG 110412-TM GK3867	1.2	•			
DNMG 150404-TM GK3867	0.4	•			
DNMG 150408-TM GK3867	0.8	•			
DNMG 150412-TM GK3867	1.2	•			
DNMG 150604-TM GK3867	0.4	•			
DNMG 150608-TM GK3867	0.8	•			
DNMG 150612-TM GK3867	1.2	•			
DNMG 110404-TM GK3877	0.4	•			
DNMG 110408-TM GK3877	0.8	•			
DNMG 110412-TM GK3877	1.2	•			
DNMG 150404-TM GK3877	0.4	•			
DNMG 150408-TM GK3877	0.8	•			
DNMG 150412-TM GK3877	1.2	•			
DNMG 150604-TM GK3877	0.4	•			
DNMG 150608-TM GK3877	0.8	•			
DNMG 150612-TM GK3877	1.2	•			
DNMG 110404-GM GK3867	0.4	•			
DNMG 110408-GM GK3867	0.8	•			
DNMG 110412-GM GK3867	1.2	•			
DNMG 150404-GM GK3867	0.4	•			
DNMG 150408-GM GK3867	0.8	•			
DNMG 150412-GM GK3867	1.2	•			
DNMG 150604-GM GK3867	0.4	•			
DNMG 150608-GM GK3867	0.8	•			
DNMG 150612-GM GK3867	1.2	•			
DNMG 110404-GM GK3877	0.4	•			
DNMG 110408-GM GK3877	0.8	•			
DNMG 110412-GM GK3877	1.2	•			
DNMG 150404-GM GK3877	0.4	•			
DNMG 150408-GM GK3877	0.8	•			
DNMG 150412-GM GK3877	1.2	•			



Ürün Kodu	R	P	M	K	N
DNMG 110404-MA GF5777	0.4		•		
DNMG 110408-MA GF5777	0.8		•		
DNMG 110412-MA GF5777	1.2		•		
DNMG 150404-MA GF5777	0.4		•		
DNMG 150408-MA GF5777	0.8		•		
DNMG 150412-MA GF5777	1.2		•		
DNMG 150604-MA GF5777	0.4		•		
DNMG 150608-MA GF5777	0.8		•		
DNMG 150612-MA GF5777	1.2		•		
DNMG 110404-MA GF6077	0.4		•		
DNMG 110408-MA GF6077	0.8		•		
DNMG 110412-MA GF6077	1.2		•		
DNMG 150404-MA GF6077	0.4		•		
DNMG 150408-MA GF6077	0.8		•		
DNMG 150412-MA GF6077	1.2		•		
DNMG 150604-MA GF6077	0.4		•		
DNMG 150608-MA GF6077	0.8		•		
DNMG 150612-MA GF6077	1.2		•		
DNMG 110404-BM GF5777	0.4		•		
DNMG 110408-BM GF5777	0.8		•		
DNMG 110412-BM GF5777	1.2		•		
DNMG 150404-BM GF5777	0.4		•		
DNMG 150408-BM GF5777	0.8		•		
DNMG 150412-BM GF5777	1.2		•		
DNMG 150604-BM GF5777	0.4		•		
DNMG 150608-BM GF5777	0.8		•		
DNMG 150612-BM GF5777	1.2		•		
DNMG 110404-BM GF6077	0.4		•		
DNMG 110408-BM GF6077	0.8		•		
DNMG 110412-BM GF6077	1.2		•		
DNMG 150404-BM GF6077	0.4		•		
DNMG 150408-BM GF6077	0.8		•		
DNMG 150412-BM GF6077	1.2		•		
DNMG 150604-BM GF6077	0.4		•		
DNMG 150608-BM GF6077	0.8		•		
DNMG 150612-BM GF6077	1.2		•		
DNMG 150604-CM GK4767	0.4			•	
DNMG 150608-CM GK4767	0.8			•	
DNMG 150612-CM GK4767	1.2			•	
DNMG 110404-CM GK4767	0.4			•	
DNMG 110408-CM GK4767	0.8			•	
DNMG 110412-CM GK4767	1.2			•	
DNMG 150404-CM GK4767	0.4			•	
DNMG 150408-CM GK4767	0.8			•	
DNMG 150412-CM GK4767	1.2			•	
DNMG 150604-CM GK4767	0.4			•	
DNMG 150608-CM GK4767	0.8			•	
DNMG 150612-CM GK4767	1.2			•	



Ürün Kodu	R	P	M	K	N
CNMG120404-AM GK3867	0.4	•			
CNMG120408-AM GK3867	0.8	•			
CNMG120412-AM GK3867	1.2	•			
CNMG120416-AM GK3867	1.6	•			
CNMG160608-AM GK3867	0.8	•			
CNMG160612-AM GK3867	1.2	•			
CNMG160616-AM GK3867	1.6	•			
CNMG190608-AM GK3867	0.8	•			
CNMG190612-AM GK3867	1.2	•			
CNMG190616-AM GK3867	1.6	•			
CNMG120404-AM GK3877	0.4	•			
CNMG120408-AM GK3877	0.8	•			
CNMG120412-AM GK3877	1.2	•			
CNMG120416-AM GK3877	1.6	•			
CNMG160608-AM GK3877	0.8	•			
CNMG160612-AM GK3877	1.2	•			
CNMG160616-AM GK3877	1.6	•			
CNMG190608-AM GK3877	0.8	•			
CNMG190612-AM GK3877	1.2	•			
CNMG190616-AM GK3877	1.6	•			
CNMG120404-TM GK3867	0.4	•			
CNMG120408-TM GK3867	0.8	•			
CNMG120412-TM GK3867	1.2	•			
CNMG160608-TM GK3867	0.8	•			
CNMG160612-TM GK3867	1.2	•			
CNMG190612-TM GK3867	1.2	•			
CNMG190616-TM GK3867	1.6	•			
CNMG190624-TM GK3867	2.4	•			
CNMG250924-TM GK3867	2.4	•			
CNMG250932-TM GK3867	3.2	•			
CNMG120404-TM GK3877	0.4	•			
CNMG120408-TM GK3877	0.8	•			
CNMG120412-TM GK3877	1.2	•			
CNMG160608-TM GK3877	0.8	•			
CNMG160612-TM GK3877	1.2	•			
CNMG190612-TM GK3877	1.2	•			
CNMG190616-TM GK3877	1.6	•			
CNMG190624-TM GK3877	2.4	•			
CNMG250924-TM GK3877	2.4	•			
CNMG250932-TM GK3877	3.2	•			



Ürün Kodu	R	P	M	K	N
CNMG120404-GM GK3867	0.4	•			
CNMG120408-GM GK3867	0.8	•			
CNMG120412-GM GK3867	1.2	•			
CNMG160608-GM GK3867	0.8	•			
CNMG160612-GM GK3867	1.2	•			
CNMG190612-GM GK3867	1.2	•			
CNMG190616-GM GK3867	1.6	•			
CNMG190624-GM GK3867	2.4	•			
CNMG250924-GM GK3867	2.4	•			
CNMG250932-GM GK3867	3.2	•			
CNMG120404-GM GK3877	0.4	•			
CNMG120408-GM GK3877	0.8	•			
CNMG120412-GM GK3877	1.2	•			
CNMG160608-GM GK3877	0.8	•			
CNMG160612-GM GK3877	1.2	•			
CNMG190612-GM GK3877	1.2	•			
CNMG190616-GM GK3877	1.6	•			
CNMG190624-GM GK3877	2.4	•			
CNMG250924-GM GK3877	2.4	•			
CNMG250932-GM GK3877	3.2	•			
CNMG 120404-MA GF5777	0.4		•		
CNMG 120408-MA GF5777	0.8		•		
CNMG 120412-MA GF5777	1.2		•		
CNMG 120404-MA GF6077	0.4		•		
CNMG 120408-MA GF6077	0.8		•		
CNMG 120412-MA GF6077	1.2		•		
CNMG 120404-BM GF5777	0.4		•		
CNMG 120408-BM GF5777	0.8		•		
CNMG 120412-BM GF5777	1.2		•		
CNMG 120404-BM GF6077	0.4		•		
CNMG 120408-BM GF6077	0.8		•		
CNMG 120412-BM GF6077	1.2		•		
CNMG 120404-WMF GF5777	0.4		•		
CNMG 120408-WMF GF5777	0.8		•		
CNMG 120404-WMF GF6077	0.4		•		
CNMG 120408-WMF GF6077	0.8		•		
CNMG120404-CM GK4767	0.4			•	
CNMG120408-CM GK4767	0.8			•	
CNMG120412-CM GK4767	1.2			•	
CNMG160608-CM GK4767	0.8			•	
CNMG160612-CM GK4767	1.2			•	
CNMG190612-CM GK4767	1.2			•	
CNMG190616-CM GK4767	1.6			•	
CNMG190624-CM GK4767	2.4			•	
CNMG 120404 NC25	0.4				•
CNMG 120408 NC25	0.8				•
CNMG 120412 NC25	1.2				•



Ürün Kodu	R	P	M	K	N
TNMG 160404-AM GK3867	0.4	•			
TNMG 160408-AM GK3867	0.8	•			
TNMG 160412-AM GK3867	1.2	•			
TNMG 220408-AM GK3867	0.8	•			
TNMG 220412-AM GK3867	1.2	•			
TNMG 160404-AM GK3877	0.4	•			
TNMG 160408-AM GK3877	0.8	•			
TNMG 160412-AM GK3877	1.2	•			
TNMG 220408-AM GK3877	0.8	•			
TNMG 220412-AM GK3877	1.2	•			
TNMG 160404-TM GK3867	0.4	•			
TNMG 160408-TM GK3867	0.8	•			
TNMG 160412-TM GK3867	1.2	•			
TNMG 220408-TM GK3867	0.8	•			
TNMG 220412-TM GK3867	1.2	•			
TNMG 160404-TM GK3877	0.4	•			
TNMG 160408-TM GK3877	0.8	•			
TNMG 160412-TM GK3877	1.2	•			
TNMG 220408-TM GK3877	0.8	•			
TNMG 220412-TM GK3877	1.2	•			
TNMG 160404-GM GK3867	0.4	•			
TNMG 160408-GM GK3867	0.8	•			
TNMG 160412-GM GK3867	1.2	•			
TNMG 220408-GM GK3867	0.8	•			
TNMG 220412-GM GK3867	1.2	•			
TNMG 160404-GM GK3877	0.4	•			
TNMG 160408-GM GK3877	0.8	•			
TNMG 160412-GM GK3877	1.2	•			
TNMG 220408-GM GK3877	0.8	•			
TNMG 220412-GM GK3877	1.2	•			
TNMG 160408L-S GK3877	0.8	•			
TNMG 160408R-S GK3877	0.8	•			



Ürün Kodu	R	P	M	K	N
TNMG 160404-MA GF5777	0.4		•		
TNMG 160408-MA GF5777	0.8		•		
TNMG 160404-MA GF5777	1.2		•		
TNMG 220408-MA GF5777	0.8		•		
TNMG 220412-MA GF5777	1.2		•		
TNMG 160404-MA GF6077	0.4		•		
TNMG 160408-MA GF6077	0.8		•		
TNMG 160404-MA GF6077	1.2		•		
TNMG 220408-MA GF6077	0.8		•		
TNMG 220412-MA GF6077	1.2		•		
TNMG 160404-BM GF5777	0.4		•		
TNMG 160408-BM GF5777	0.8		•		
TNMG 160404-BM GF5777	1.2		•		
TNMG 220408-BM GF5777	0.8		•		
TNMG 220412-BM GF5777	1.2		•		
TNMG 160404-BM GF6077	0.4		•		
TNMG 160408-BM GF6077	0.8		•		
TNMG 160404-BM GF6077	1.2		•		
TNMG 220408-BM GF6077	0.8		•		
TNMG 220412-BM GF6077	1.2		•		
TNMG 160404-WMF GF5777	0.4		•		
TNMG 160408-WMF GF5777	0.8		•		
TNMG 160404-WMF GF6077	0.4		•		
TNMG 160408-WMF GF6077	0.8		•		
TNMG 160408L-S GF5777	0.8		•		
TNMG 160408R-S GF5777	0.8		•		
TNMG 160408L-S GF6077	0.8		•		
TNMG 160408R-S GF6077	0.8		•		
TNMG 160404-CM GK4767	0.4			•	
TNMG 160408-CM GK4767	0.8			•	
TNMG 160412-CM GK4767	1.2			•	
TNMG 220408-CM GK4767	0.8			•	
TNMG 220412-CM GK4767	1.2			•	
TNMG 160404 NC25	0.4				•
TNMG 160408 NC25	0.8				•
TNMG 160412 NC25	1.2				•



Ürün Kodu	R	P	M	K	N
SNMG 120404-AM GK3867	0.4	•			
SNMG 120408-AM GK3867	0.8	•			
SNMG 120412-AM GK3867	1.2	•			
SNMG 150608-AM GK3867	0.8	•			
SNMG 150612-AM GK3867	1.2	•			
SNMG 190612-AM GK3867	1.2	•			
SNMG 190616-AM GK3867	1.6	•			
SNMG 190624-AM GK3867	2.4	•			
SNMG 120404-AM GK3877	0.4	•			
SNMG 120408-AM GK3877	0.8	•			
SNMG 120412-AM GK3877	1.2	•			
SNMG 150608-AM GK3877	0.8	•			
SNMG 150612-AM GK3877	1.2	•			
SNMG 190612-AM GK3877	1.2	•			
SNMG 190616-AM GK3877	1.6	•			
SNMG 190624-AM GK3877	2.4	•			
SNMG 120404-TM GK3867	0.4	•			
SNMG 120408-TM GK3867	0.8	•			
SNMG 120412-TM GK3867	1.2	•			
SNMG 150608-TM GK3867	0.8	•			
SNMG 150612-TM GK3867	1.2	•			
SNMG 190612-TM GK3867	1.2	•			
SNMG 190616-TM GK3867	1.6	•			
SNMG 190624-TM GK3867	2.4	•			
SNMG 120404-TM GK3877	0.4	•			
SNMG 120408-TM GK3877	0.8	•			
SNMG 120412-TM GK3877	1.2	•			
SNMG 150608-TM GK3877	0.8	•			
SNMG 150612-TM GK3877	1.2	•			
SNMG 190612-TM GK3877	1.2	•			
SNMG 190616-TM GK3877	1.6	•			
SNMG 190624-TM GK3877	2.4	•			
SNMG 120404-GM GK3867	0.4	•			
SNMG 120408-GM GK3867	0.8	•			
SNMG 120412-GM GK3867	1.2	•			
SNMG 150608-GM GK3867	0.8	•			
SNMG 150612-GM GK3867	1.2	•			
SNMG 190612-GM GK3867	1.2	•			
SNMG 190616-GM GK3867	1.6	•			
SNMG 190624-GM GK3867	2.4	•			
SNMG 120404-GM GK3877	0.4	•			
SNMG 120408-GM GK3877	0.8	•			
SNMG 120412-GM GK3877	1.2	•			
SNMG 150608-GM GK3877	0.8	•			
SNMG 150612-GM GK3877	1.2	•			
SNMG 190612-GM GK3877	1.2	•			
SNMG 190616-GM GK3877	1.6	•			
SNMG 190624-GM GK3877	2.4	•			
SNMG 250924-GR GK3867	2.4	•			
SNMG 250932-GR GK3867	3.2	•			
SNMG 250924-GR GK3877	2.4	•			
SNMG 250932-GR GK3877	3.2	•			



Ürün Kodu	R	P	M	K	N
SNMG 120404-MA GF5777	0.4		•		
SNMG 120408-MA GF5777	0.8		•		
SNMG 120412-MA GF5777	1.2		•		
SNMG 150608-MA GF5777	0.8		•		
SNMG 150612-MA GF5777	1.2		•		
SNMG 190612-MA GF5777	1.2		•		
SNMG 190616-MA GF5777	1.6		•		
SNMG 190624-MA GF5777	2.4		•		
SNMG 120404-MA GF6077	0.4		•		
SNMG 120408-MA GF6077	0.8		•		
SNMG 120412-MA GF6077	1.2		•		
SNMG 150608-MA GF6077	0.8		•		
SNMG 150612-MA GF6077	1.2		•		
SNMG 190612-MA GF6077	1.2		•		
SNMG 190616-MA GF6077	1.6		•		
SNMG 190624-MA GF6077	2.4		•		
SNMG 120404-BM GF5777	0.4		•		
SNMG 120408-BM GF5777	0.8		•		
SNMG 120412-BM GF5777	1.2		•		
SNMG 150608-BM GF5777	0.8		•		
SNMG 150612-BM GF5777	1.2		•		
SNMG 190612-BM GF5777	1.2		•		
SNMG 190616-BM GF5777	1.6		•		
SNMG 190624-BM GF5777	2.4		•		
SNMG 120404-BM GF6077	0.4		•		
SNMG 120408-BM GF6077	0.8		•		
SNMG 120412-BM GF6077	1.2		•		
SNMG 150608-BM GF6077	0.8		•		
SNMG 150612-BM GF6077	1.2		•		
SNMG 190612-BM GF6077	1.2		•		
SNMG 190616-BM GF6077	1.6		•		
SNMG 190624-BM GF6077	2.4		•		
SNMG 120404-CM GK4767	0.4			•	
SNMG 120408-CM GK4767	0.8			•	
SNMG 120412-CM GK4767	1.2			•	
SNMG 150608-CM GK4767	0.8			•	
SNMG 150612-CM GK4767	1.2			•	
SNMG 190612-CM GK4767	1.2			•	
SNMG 190616-CM GK4767	1.6			•	
SNMG 190624-CM GK4767	2.4			•	
SNMG 120404 NC25	0.4				•
SNMG 120408 NC25	0.8				•
SNMG 120412 NC25	1.2				•



Ürün Kodu	R	P	M	K	N
VNMG 160404-AM GK3867	0.4	•			
VNMG 160408-AM GK3867	0.8	•			
VNMG 160412-AM GK3867	1.2	•			
VNMG 160404-AM GK3877	0.4	•			
VNMG 160408-AM GK3877	0.8	•			
VNMG 160412-AM GK3877	1.2	•			
VNMG 160404-TM GK3867	0.4	•			
VNMG 160408-TM GK3867	0.8	•			
VNMG 160412-TM GK3867	1.2	•			
VNMG 160404-TM GK3877	0.4	•			
VNMG 160408-TM GK3877	0.8	•			
VNMG 160412-TM GK3877	1.2	•			
VNMG 160404-GM GK3867	0.4	•			
VNMG 160408-GM GK3867	0.8	•			
VNMG 160412-GM GK3867	1.2	•			
VNMG 160404-GM GK3877	0.4	•			
VNMG 160408-GM GK3877	0.8	•			
VNMG 160412-GM GK3877	1.2	•			
VNMG 160404-MA GF5777	0.4		•		
VNMG 160408-MA GF5777	0.8		•		
VNMG 160404-MA GF5777	1.2		•		
VNMG 160404-MA GF6077	0.4		•		
VNMG 160408-MA GF6077	0.8		•		
VNMG 160404-MA GF6077	1.2		•		
VNMG 160404-BM GF5777	0.4		•		
VNMG 160408-BM GF5777	0.8		•		
VNMG 160404-BM GF5777	1.2		•		
VNMG 160404-BM GF6077	0.4		•		
VNMG 160408-BM GF6077	0.8		•		
VNMG 160404-BM GF6077	1.2		•		
VNMG 160404-WMF GF5777	0.4		•		
VNMG 160408-WMF GF5777	0.8		•		
VNMG 160404-WMF GF6077	0.4		•		
VNMG 160408-WMF GF6077	0.8		•		
VNMG 160404-CM GK4767	0.4			•	
VNMG 160408-CM GK4767	0.8			•	
VNMG 160412-CM GK4767	1.2			•	
VNMG 160404 NC25	0.4				•
VNMG 160408 NC25	0.8				•
VNMG 160412 NC25	1.2				•



Ürün Kodu	R	P	M	K	N
VBMT 160404-JW GK3667	0.4	•		•	
VBMT 160408-JW GK3667	0.8	•		•	
VBMT 160412-JW GK3667	1.2	•		•	
VBMT 160404-JW GK3677	0.4	•		•	
VBMT 160408-JW GK3677	0.8	•		•	
VBMT 160412-JW GK3677	1.2	•		•	
VBMT 160404-JW GK3867	0.4	•		•	
VBMT 160408-JW GK3867	0.8	•		•	
VBMT 160412-JW GK3867	1.2	•		•	
VBMT 160404-JW GK3877	0.4	•		•	
VBMT 160408-JW GK3877	0.8	•		•	
VBMT 160412-JW GK3877	1.2	•		•	
VCMT 110304-HH GK3667	0.4	•		•	
VCMT 110308-HH GK3667	0.8	•		•	
VCMT 110312-HH GK3667	1.2	•		•	
VCMT 160404-HH GK3667	0.4	•		•	
VCMT 160408-HH GK3667	0.8	•		•	
VCMT 160412-HH GK3667	1.2	•		•	
VCMT 110304-HH GK3677	0.4	•		•	
VCMT 110308-HH GK3677	0.8	•		•	
VCMT 110312-HH GK3677	1.2	•		•	
VCMT 160404-HH GK3677	0.4	•		•	
VCMT 160408-HH GK3677	0.8	•		•	
VCMT 160412-HH GK3677	1.2	•		•	
VCMT 110304-HH GK3867	0.4	•		•	
VCMT 110308-HH GK3867	0.8	•		•	
VCMT 110312-HH GK3867	1.2	•		•	
VCMT 160404-HH GK3867	0.4	•		•	
VCMT 160408-HH GK3867	0.8	•		•	
VCMT 160412-HH GK3867	1.2	•		•	
VCMT 110304-HH GK3877	0.4	•		•	
VCMT 110308-HH GK3877	0.8	•		•	
VCMT 110312-HH GK3877	1.2	•		•	
VCMT 160404-HH GK3877	0.4	•		•	
VCMT 160408-HH GK3877	0.8	•		•	
VCMT 160412-HH GK3877	1.2	•		•	



Ürün Kodu	R	P	M	K	N
VBMT 160404-JW GF5777	0.4		•		
VBMT 160408-JW GF5777	0.8		•		
VBMT 160412-JW GF5777	1.2		•		
VBMT 160404-JW GF6077	0.4		•		
VBMT 160408-JW GF6077	0.8		•		
VBMT 160412-JW GF6077	1.2		•		
VBMT 160404-MM GF5777	0.4		•		
VBMT 160408-MM GF5777	0.8		•		
VBMT 160412-MM GF5777	1.2		•		
VBMT 160404-MM GF6077	0.4		•		
VBMT 160408-MM GF6077	0.8		•		
VBMT 160412-MM GF6077	1.2		•		
VCMT 110304-HH GF5777	0.4		•		
VCMT 110308-HH GF5777	0.8		•		
VCMT 110312-HH GF5777	1.2		•		
VCMT 160404-HH GF5777	0.4		•		
VCMT 160408-HH GF5777	0.8		•		
VCMT 160412-HH GF5777	1.2		•		
VCMT 110304-HH GF6077	0.4		•		
VCMT 110308-HH GF6077	0.8		•		
VCMT 110312-HH GF6077	1.2		•		
VCMT 160404-HH GF6077	0.4		•		
VCMT 160408-HH GF6077	0.8		•		
VCMT 160412-HH GF6077	1.2		•		
VCGT 110302-NC25	0.2				•
VCGT 110304-NC25	0.4				•
VCGT 110308-NC25	0.8				•
VCGT 160402-NC25	0.2				•
VCGT 160404-NC25	0.4				•
VCGT 160408-NC25	0.8				•



Ürün Kodu	R	P	M	K	N
DCMT 070204-JW GK3667	0.4	•		•	
DCMT 070208-JW GK3667	0.8	•		•	
DCMT 070204-JW GK3677	0.4	•		•	
DCMT 070208-JW GK3677	0.8	•		•	
DCMT 070204-JW GK3867	0.4	•		•	
DCMT 070208-JW GK3867	0.8	•		•	
DCMT 070204-JW GK3877	0.4	•		•	
DCMT 070208-JW GK3877	0.8	•		•	
DCMT 11T304-JW GK3667	0.4	•		•	
DCMT 11T308-JW GK3667	0.8	•		•	
DCMT 11T304-JW GK3677	0.4	•		•	
DCMT 11T308-JW GK3677	0.8	•		•	
DCMT 11T304-JW GK3867	0.4	•		•	
DCMT 11T308-JW GK3867	0.8	•		•	
DCMT 11T304-JW GK3877	0.4	•		•	
DCMT 11T308-JW GK3877	0.8	•		•	
DCMT 070204-JW GF5777	0.4		•		
DCMT 070208-JW GF5777	0.8		•		
DCMT 070204-JW GF6077	0.4		•		
DCMT 070208-JW GF6077	0.8		•		
DCMT 11T304-JW GF5777	0.4		•		
DCMT 11T308-JW GF5777	0.8		•		
DCMT 11T304-JW GF6077	0.4		•		
DCMT 11T308-JW GF6077	0.8		•		
DCMT 11T304-MM GF5777	0.4		•		
DCMT 11T308-MM GF5777	0.8		•		
DCMT 11T304-MM GF6077	0.4		•		
DCMT 11T308-MM GF6077	0.8		•		
DCGT 11T302 NC25	0.2				•
DCGT 11T304 NC25	0.4				•
DCGT 11T308 NC25	0.8				•



Ürün Kodu	R	P	M	K	N
CCMT 060204-JW GK3667	0.4	•		•	
CCMT 060208-JW GK3667	0.8	•		•	
CCMT 060204-JW GK3677	0.4	•		•	
CCMT 060208-JW GK3677	0.8	•		•	
CCMT 060204-JW GK3867	0.4	•		•	
CCMT 060208-JW GK3867	0.8	•		•	
CCMT 060204-JW GK3877	0.4	•		•	
CCMT 060208-JW GK3877	0.8	•		•	
CCMT 09T304-JW GK3667	0.4	•		•	
CCMT 09T308-JW GK3667	0.8	•		•	
CCMT 09T304-JW GK3677	0.4	•		•	
CCMT 09T308-JW GK3677	0.8	•		•	
CCMT 09T304-JW GK3867	0.4	•		•	
CCMT 09T308-JW GK3867	0.8	•		•	
CCMT 09T304-JW GK3877	0.4	•		•	
CCMT 09T308-JW GK3877	0.8	•		•	
CCMT 120404-JW GK3667	0.4	•		•	
CCMT 120408-JW GK3667	0.8	•		•	
CCMT 120404-JW GK3677	0.4	•		•	
CCMT 120408-JW GK3677	0.8	•		•	
CCMT 120404-JW GK3867	0.4	•		•	
CCMT 120408-JW GK3867	0.8	•		•	
CCMT 120404-JW GK3877	0.4	•		•	
CCMT 120408-JW GK3877	0.8	•		•	
CCMT 060204-JW GF5777	0.4		•		
CCMT 060208-JW GF5777	0.8		•		
CCMT 060204-JW GF6077	0.4		•		
CCMT 060208-JW GF6077	0.8		•		
CCMT 09T304-JW GF5777	0.4		•		
CCMT 09T308-JW GF5777	0.8		•		
CCMT 09T304-JW GF6077	0.4		•		
CCMT 09T308-JW GF6077	0.8		•		
CCMT 120404-JW GF5777	0.4		•		
CCMT 120408-JW GF5777	0.8		•		
CCMT 120404-JW GF6077	0.4		•		
CCMT 120408-JW GF6077	0.8		•		
CCGT 09T302 NC25	0.2				•
CCGT 09T304 NC25	0.4				•
CCGT 09T308 NC25	0.8				•
CCGT 120404 NC25	0.4				•
CCGT 120408 NC25	0.8				•
CCGT 120412 NC25	1.2				•



Ürün Kodu	R	P	M	K	N
TCMT 110204-JW GK3667	0.4	•		•	
TCMT 110208-JW GK3667	0.8	•		•	
TCMT 16T304-JW GK3667	0.4	•		•	
TCMT 16T308-JW GK3667	0.8	•		•	
TCMT 110204-JW GK3677	0.4	•		•	
TCMT 110208-JW GK3677	0.8	•		•	
TCMT 16T304-JW GK3677	0.4	•		•	
TCMT 16T308-JW GK3677	0.8	•		•	
TCMT 110204-JW GK3867	0.4	•		•	
TCMT 110208-JW GK3867	0.8	•		•	
TCMT 16T304-JW GK3867	0.4	•		•	
TCMT 16T308-JW GK3867	0.8	•		•	
TCMT 110204-JW GK3877	0.4	•		•	
TCMT 110208-JW GK3877	0.8	•		•	
TCMT 16T304-JW GK3877	0.4	•		•	
TCMT 16T308-JW GK3877	0.8	•		•	
TCMT 110204-JW GF5777	0.4		•		
TCMT 110208-JW GF5777	0.8		•		
TCMT 16T304-JW GF5777	0.4		•		
TCMT 16T308-JW GF5777	0.8		•		
TCMT 110204-JW GF6077	0.4		•		
TCMT 110208-JW GF6077	0.8		•		
TCMT 16T304-JW GF6077	0.4		•		
TCMT 16T308-JW GF6077	0.8		•		
TCGT 090204 NC25	0.4				•
TCGT 110204 NC25	0.4				•
TCGT 16T304 NC25	0.8				•
TCGT 16T308 NC25	0.8				•



Ürün Kodu	R	P	M	K	N
SCMT 09T304-JW GK3667	0.4	•		•	
SCMT 09T308-JW GK3667	0.8	•		•	
SCMT 120404-JW GK3667	0.4	•		•	
SCMT 120408-JW GK3667	0.8	•		•	
SCMT 09T304-JW GK3677	0.4	•		•	
SCMT 09T308-JW GK3677	0.8	•		•	
SCMT 120404-JW GK3677	0.4	•		•	
SCMT 120408-JW GK3677	0.8	•		•	
SCMT 09T304-JW GK3867	0.4	•		•	
SCMT 09T308-JW GK3867	0.8	•		•	
SCMT 120404-JW GK3867	0.4	•		•	
SCMT 120408-JW GK3867	0.8	•		•	
SCMT 09T304-JW GK3877	0.4	•		•	
SCMT 09T308-JW GK3877	0.8	•		•	
SCMT 120404-JW GK3877	0.4	•		•	
SCMT 120408-JW GK3877	0.8	•		•	
SCMT 09T304-JW GF5777	0.4		•		
SCMT 09T308-JW GF5777	0.8		•		
SCMT 120404-JW GF5777	0.4		•		
SCMT 120408-JW GF5777	0.8		•		
SCMT 09T304-JW GF6077	0.4		•		
SCMT 09T308-JW GF6077	0.8		•		
SCMT 120404-JW GF6077	0.4		•		
SCMT 120408-JW GF6077	0.8		•		
SCGT 09T302 NC25	0.2				•
SCGT 09T304 NC25	0.4				•
SCGT 120402 NC25	0.2				•
SCGT 120404 NC25	0.4				•



KESME



Ürün Kodu	R	P	M	K	N
MGMN 200-M GK3877	0.2	•		•	
MGMN 300-M GK3877	0.4	•		•	
MGMN 400-M GK3877	0.4	•		•	
MGMN 500-M GK3877	0.8	•		•	
MGMN 600-M GK3877	0.8	•		•	
MGMN 200-M GF5777	0.2		•		
MGMN 300-M GF5777	0.4		•		
MGMN 400-M GF5777	0.4		•		
MGMN 500-M GF5777	0.8		•		
MGMN 600-M GF5777	0.8		•		
MGMN 200-M GF6077	0.2		•		
MGMN 300-M GF6077	0.4		•		
MGMN 400-M GF6077	0.4		•		
MGMN 500-M GF6077	0.8		•		
MGMN 600-M GF6077	0.8		•		
MRMN 200-M GK3877	1	•		•	
MRMN 300-M GK3877	1.5	•		•	
MRMN 400-M GK3877	2	•		•	
MRMN 500-M GK3877	2.5	•		•	
MRMN 600-M GK3877	3	•		•	
MRMN 200-M GF5777	1		•		
MRMN 300-M GF5777	1.5		•		
MRMN 400-M GF5777	2		•		
MRMN 500-M GF5777	2.5		•		
MRMN 600-M GF5777	3		•		
MRMN 200-M GF6077	1		•		
MRMN 300-M GF6077	1.5		•		
MRMN 400-M GF6077	2		•		
MRMN 500-M GF6077	2.5		•		
MRMN 600-M GF6077	3		•		
ZTFD 0303-MG GF5777	0.3		•		
ZTGD 0404-MG GF5777	0.4		•		
ZTHD 0504-MG GF5777	0.8		•		
ZTFD 0303-MG GF6077	0.3		•		
ZTGD 0404-MG GF6077	0.4		•		
ZTHD 0504-MG GF6077	0.4		•		
A4G0305M03-GK3877	0.4	•		•	
A4G0305M04-GK3877	0.8	•		•	
A4G0305M05-GK3877	0.8	•		•	
A4G0305M06-GK3877	0.8	•		•	
A4R0305M03-GK3877	1.5	•		•	
A4R0305M04-GK3877	2	•		•	
A4R0305M05-GK3877	2.5	•		•	
A4R0305M06-GK3877	3	•		•	

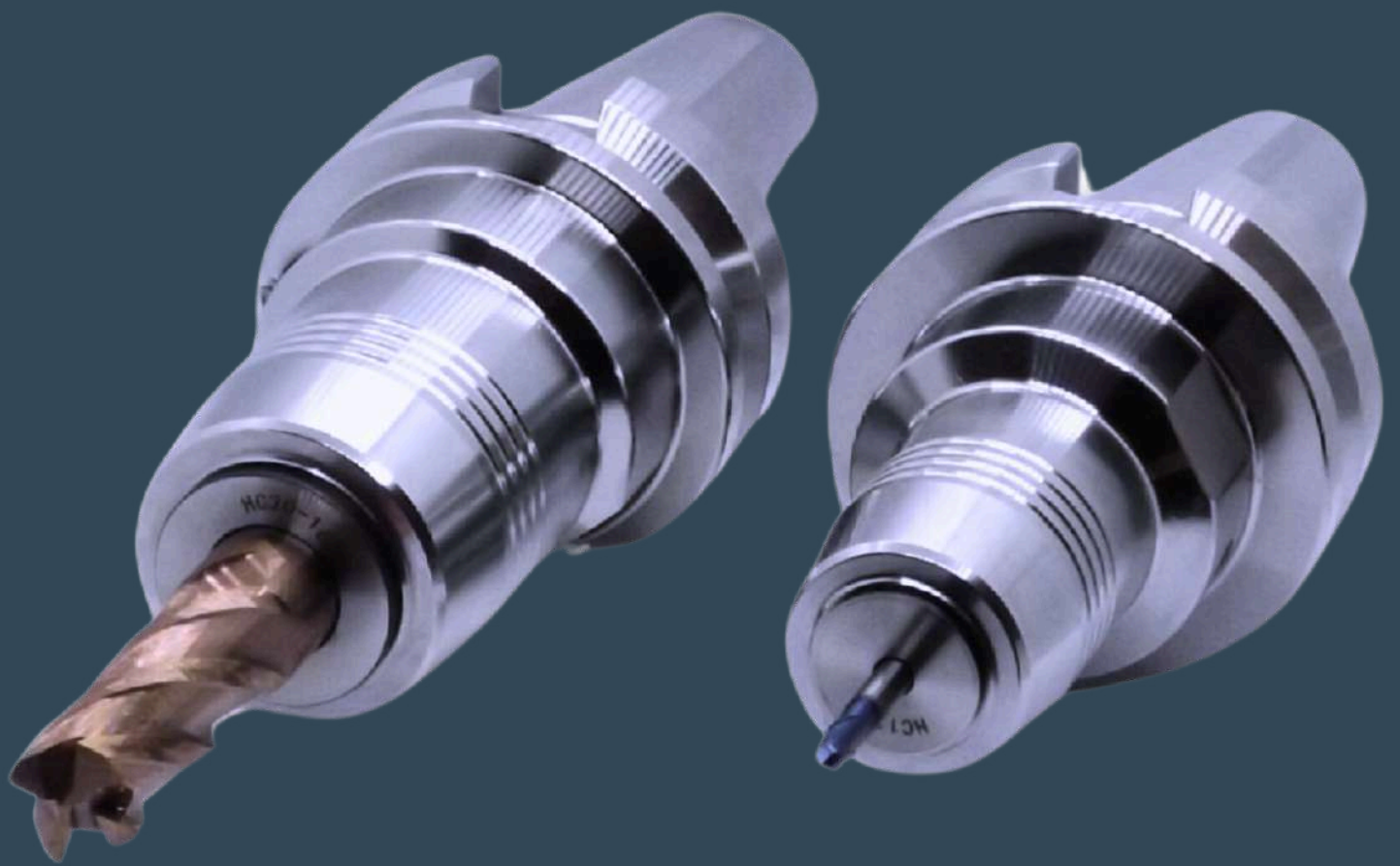

# Takım Tutucu

- BT
- BBT
- SK
- HSK-A





BT

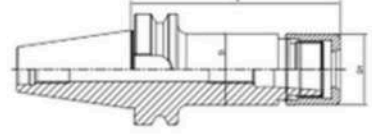

Ürün Kodu	Konik	D	D1	L	Aralık	
BT30-SKS10-060	BT30	27.5	27.1	60	2-10	
BT30-SKS10-090				90		
BT30-SKS16-060	BT30	40.6	40	60	3-16	
BT30-SKS16-090				90		
BT40-SKS06-060	BT40	20	19	60	2-6	
BT40-SKS06-090				90		
BT40-SKS10-060		27.5	27.1	60	2-10	
BT40-SKS10-090				90		
BT40-SKS10-120				120		
BT40-SKS16-070		40.6	40	70	3-16	
BT40-SKS16-090				90		
BT40-SKS16-120				120		
BT40-SKS25-090		55.6	55	90	6-25	
BT40-SKS25-120				120		
BT50-SKS10-100		BT50	27.5	27.1	100	2-10
BT50-SKS10-120					120	
BT50-SKS10-165				165		
BT50-SKS16-100	40.6		40	100	3-16	
BT50-SKS16-120				120		
BT50-SKS16-165				165		
BT50-SKS25-100	55.6		55	100	6-25	



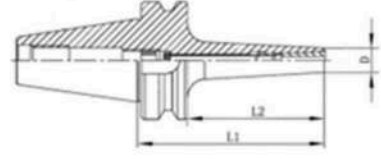

Ürün Kodu	Konik	D	L1	L2	Aralık
BT30-SDC06-060	BT30	14	60	38	3-6
BT30-SDC06-090			90	68	
BT30-SDC08-060		22	60	38	3-8
BT30-SDC08-090			90	68	
BT30-SDC12-080		34	80	58	3-12
BT40-SDC06-060		BT40	14	60	33
BT40-SDC06-090	90			63	
BT40-SDC06-120	120			93	
BT40-SDC06-150	150			123	
BT40-SDC08-060	22		60	33	3-8
BT40-SDC08-090			90	63	
BT40-SDC08-120			120	93	
BT40-SDC08-150			150	123	
BT40-SDC08-200	34		200	173	3-12
BT40-SDC12-090			90	63	
BT40-SDC12-120			120	93	
BT40-SDC12-150			150	123	
BT40-SDC12-200	200	173			
BT50-SDC06-100	BT50	14	100	62	3-6
BT50-SDC06-150			150	112	
BT50-SDC08-100		22	100	62	3-8
BT50-SDC08-150			150	112	
BT50-SDC08-200			200	162	
BT50-SDC12-100		34	100	62	3-12
BT50-SDC12-150			150	112	
BT50-SDC12-200			200	162	

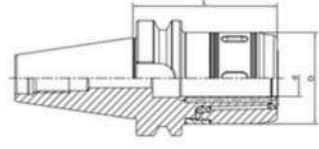

Ürün Kodu	Konik	d	D	L	Aralık
BT30-HC20-080	BT30	20	50	80	3-20
BT30-HC25-090		25	59	90	3-25
BT30-HC32-110		32	70	110	3-32
BT40-HC20-090	BT40	20	50	90	3-20
BT40-HC25-100		25	59	100	3-25
BT40-HC32-090		32	70	90	3-32
BT40-HC32-105		32	70	105	3-32
BT40-HC42-130		42	99	130	3-42
BT50-HC20-105	BT50	20	50	105	3-20
BT50-HC25-105		25	59	105	3-25
BT50-HC32-110		32	70	110	3-32
BT50-HC32-165		32	70	165	3-32
BT50-HC42-110		42	99	110	3-42
BT50-HC42-165		42	99	165	3-42

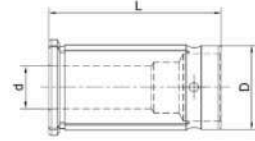

Ürün Kodu	d	D	L
SC16	3,4,5,6,8,10,12	16	45
SC20	3,4,5,6,8,10,12,14,16	20	50
SC22	3,4,5,6,8,10,12,14,16	22	54
SC25	3,4,5,6,8,10,12,14,16,18,20	25	60
SC32	3,4,5,6,8,10,12,14,16,18,20,25	32	64
SC40	6,8,10,12,14,16,18,20,25,28,30,32	40	80
SC42	3,4,5,6,8,10,12,14,16,18,20,22,24,25,28,30,32	42	80

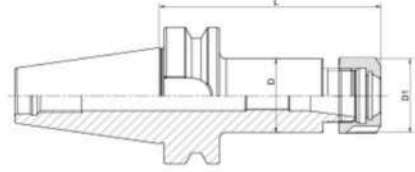

ÜrünKodu	Konik	D	D1	L	Kapasite
BT30-ER16UM-070	BT30	28	32	70	1-10
BT30-ER16UM-100		28	32	100	1-10
BT30-ER20UM-070		34	35	70	1-13
BT30-ER20UM-100		34	35	100	1-13
BT30-ER25-070		42	42	70	2-16
BT30-ER25-100		42	42	100	2-16
BT30-ER32-070		50	50	70	2-20
BT30-ER32-100		50	50	100	2-20
BT30-ER40-080		50	63	80	3-26
BT40-ER16UM-063		BT40	28	32	63
BT40-ER16UM-100	28		32	100	1-10
BT40-ER16UM-160	28		32	160	1-10
BT40-ER20UM-070	34		35	70	1-13
BT40-ER20UM-100	34		35	100	1-13
BT40-ER20UM-160	34		35	160	1-13
BT40-ER25-070	42		42	70	2-16
BT40-ER25-100	42		42	100	2-16
BT40-ER25-160	42		42	160	2-16
BT40-ER32-070	50		50	70	2-20
BT40-ER32-100	50		50	100	2-20
BT40-ER32-160	50		50	160	2-20
BT40-ER40-080	50		63	80	3-26
BT40-ER40-100	50		63	100	3-26
BT40-ER40-160	50		63	160	3-26
BT50-ER16UM-070	BT50		28	32	70
BT50-ER16UM-100		28	32	100	1-10
BT50-ER16UM-160		28	32	160	1-10
BT50-ER20UM-070		34	35	70	1-13
BT50-ER20UM-100		34	35	100	1-13
BT50-ER20UM-160		34	35	160	1-13
BT50-ER25-070		42	42	70	2-16
BT50-ER25-100		42	42	100	2-16
BT50-ER25-160		42	42	160	2-16
BT50-ER32-070		50	50	70	2-20
BT50-ER32-100		50	50	100	2-20
BT50-ER32-160		50	50	160	2-20
BT50-ER32-200		50	50	200	2-20
BT50-ER40-080		50	63	80	3-26
BT50-ER40-100		50	63	100	3-26
BT50-ER40-160		50	63	160	3-26
BT50-ER40-200	50	63	200	3-26	

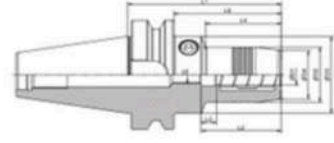

Ürün Kodu	Konik	D1	D2	L2	L5
BT30-HY06-070	BT30	6	26	38	48
BT30-HY08-070		8	28	38	48
BT30-HY10-075		10	30	42	53
BT30-HY12-085		12	32	47	63
BT30-HY14-085		14	34	47	63
BT30-HY16-090		16	38	50	68
BT30-HY18-090		18	40	50	68
BT30-HY20-090		20	42	52	68
BT40-HY06-090	BT40	6	26	38	63
BT40-HY08-090		8	28	38	63
BT40-HY10-090		10	30	42	63
BT40-HY12-090		12	32	47	63
BT40-HY14-090		14	34	47	63
BT40-HY16-090		16	38	50	63
BT40-HY18-090		18	40	50	63
BT40-HY20-090		20	42	52	63
BT40-HY25-100		25	57	58	73
BT40-HY32-105		32	62	62	78

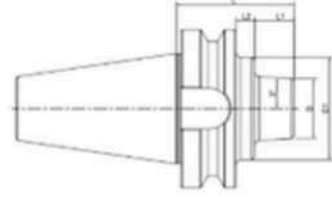

Ürün Kodu	Konik	D	L	L1	Aralık
BT30-TSF12-35	BT30	38	35	13	3-12
BT40-TSF12-45	BT40		45	18	3-12
BT40-TSF12-75			75	48	3-12
BT50-TSF12-75			BT50	75	25
BT50-TSF12-225	225			175	3-12
BT50-TSF12-315	315			225	3-12

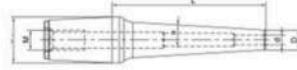

Ürün Kodu	d	D	L	$\alpha$	M
12-SF3-55S	3	6	55	3	M10
12-SF3-80S			80		
12-SF3-110S			110		
12-SF4-55S	4	7	55	3	M10
12-SF4-80S			80		
12-SF4-110S			110		
12-SF5-55S	5	8	55	3	M10
12-SF5-80S			80		
12-SF5-110S			110		
12-SF6-55S	6	9	55	3	M10
12-SF6-80S			80		
12-SF6-110S			110		
12-SF8-55S	8	11	55	3	M10
12-SF8-80S			80		
12-SF8-110S			110		
12-SF10-55S	10	13	55	3	M10
12-SF10-80S			80		
12-SF10-110S			110		
12-SF12-55S	12	15	55	3	M10
12-SF12-80S			80		
12-SF12-110S			110		

genco  
makina

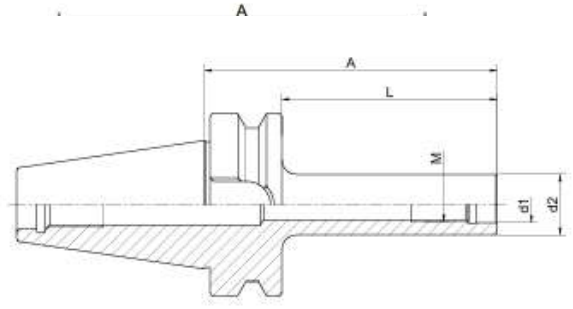

Ürün Kodu	Konik	M	d2	L	A
BT40-M10-102	BT40	M10	18	75	102
BT40-M10-127				100	127
BT40-M10-177				150	177
BT40-M12-102		M12	21	75	102
BT40-M12-127				100	127
BT40-M12-152				125	152
BT40-M12-177				150	177
BT40-M16-102		M16	29	130	102
BT40-M16-127				105	127
BT40-M16-152				105	152
BT40-M16-177				110	177
BT50-M10-138				BT50	M10
BT50-M10-188	188	150			
BT50-M12-138	M12	21	138		100
BT50-M12-188			188		150
BT50-M16-138	M16	29	138		100
BT50-M16-188			188		150



**BBT**

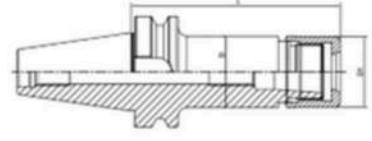

Ürün Kodu	Konik	D	D1	L	Aralık
BBT40-SKS10-090	BBT40	27.5	27.1	90	2-10
BBT40-SKS10-120				120	
BBT40-SKS16-090		40.6	40	90	3-16
BBT40-SKS16-120				120	
BBT50-SKS10-100	BBT50	27.5	27.1	100	2-10
BBT50-SKS10-120				120	
BBT50-SKS10-165				165	
BBT50-SKS16-100		40.6	40	100	3-16
BBT50-SKS16-120				120	
BBT50-SKS16-165				165	



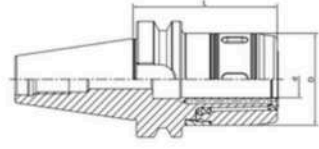

Ürün Kodu	Konik	d	D	L	Aralık
BBT40-HC20-090	BBT40	20	50	90	3-20
BBT40-HC25-100		25	59	100	3-25
BBT40-HC32-090		32	70	90	3-32
BBT40-HC32-105		32	70	105	3-32
BBT50-HC20-105	BBT50	20	50	105	3-20
BBT50-HC25-105		25	59	105	3-25
BBT50-HC32-110		32	70	110	3-32
BBT50-HC32-165		32	70	165	3-32

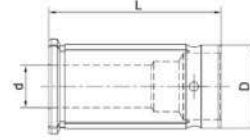

Ürün Kodu	Konik	D	L
SC16	3,4,5,6,8,10,12	16	45
SC20	3,4,5,6,8,10,12,14,16	20	50
SC22	3,4,5,6,8,10,12,14,16	22	54
SC25	3,4,5,6,8,10,12,14,16,18,20	25	60
SC32	3,4,5,6,8,10,12,14,16,18,20,25	32	64
SC40	6,8,10,12,14,16,18,20,25,28,30,32	40	80
SC42	3,4,5,6,8,10,12,14,16,18,20,22,24,25,28,30,32	42	80

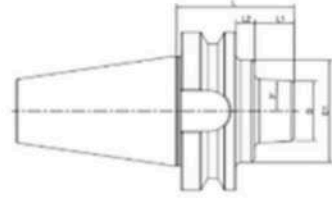

Ürün Kodu	Konik	D	L	L1	Aralık
BBT30-TSF12-35	BBT30	38	35	13	3-12
BBT40-TSF12-45	BBT40		45	18	3-12
BBT40-TSF12-75			75	48	3-12
BBT50-TSF12-75			BBT50	75	25
BBT50-TSF12-225	225			175	3-12
BBT50-TSF12-315	315			225	3-12

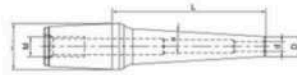

Ürün Kodu	d	D	L	$\alpha$	M
12-SF3-55S	3	6	55	3	M10
12-SF3-80S			80		
12-SF3-110S			110		
12-SF4-55S	4	7	55	3	M10
12-SF4-80S			80		
12-SF4-110S			110		
12-SF5-55S	5	8	55	3	M10
12-SF5-80S			80		
12-SF5-110S			110		
12-SF6-55S	6	9	55	3	M10
12-SF6-80S			80		
12-SF6-110S			110		
12-SF8-55S	8	11	55	3	M10
12-SF8-80S			80		
12-SF8-110S			110		
12-SF10-55S	10	13	55	3	M10
12-SF10-80S			80		
12-SF10-110S			110		
12-SF12-55S	12	15	55	3	M10
12-SF12-80S			80		
12-SF12-110S			110		



SK

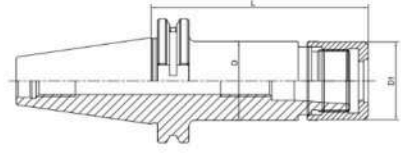

Ürün Kodu	Konik	D	D1	L	Aralık
SK40-SKS10-060	SK40	27.5	27.1	60	2-10
SK40-SKS10-090				90	
SK40-SKS10-120				120	
SK40-SKS16-060	SK40	40.6	40	60	3-16
SK40-SKS16-090				90	
SK40-SKS16-120				120	
SK50-SKS10-105	SK50	27.5	27.1	105	2-10
SK50-SKS10-135				135	
SK50-SKS10-165				165	
SK50-SKS16-105	SK50	40.6	40	105	3-16
SK50-SKS16-135				135	
SK50-SKS16-165				165	



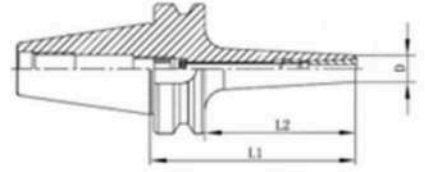

Ürün Kodu	Konik	D	L1	L2	Aralık
SK30-SDC06-060	SK30	14	60	38	3-6
SK30-SDC06-090			90	68	
SK30-SDC06-120			120	98	
SK30-SDC08-060		22	60	38	3-8
SK30-SDC08-090			90	68	
SK30-SDC08-120			120	98	
SK30-SDC12-080	34	80	58	3-12	
SK40-SDC06-060	SK40	14	60	33	3-6
SK40-SDC06-090			90	63	
SK40-SDC06-120			120	93	
SK40-SDC06-150			150	123	
SK40-SDC08-060		22	60	33	3-8
SK40-SDC08-090			90	63	
SK40-SDC08-120			120	93	
SK40-SDC08-150			150	123	
SK40-SDC08-200		34	200	173	3-12
SK40-SDC12-090			90	63	
SK40-SDC12-120			120	93	
SK40-SDC12-150			150	123	
SK40-SDC12-200	200	173			
SK50-SDC06-110	SK50	14	110	72	3-6
SK50-SDC06-150			150	112	
SK50-SDC08-110		22	100	72	3-8
SK50-SDC08-150			150	112	
SK50-SDC08-200			200	162	
SK50-SDC12-120		34	100	82	3-12
SK50-SDC12-150			150	112	
SK50-SDC12-200			200	162	

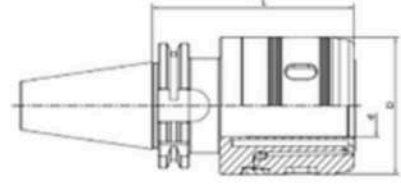

Ürün Kodu	Konik	d	D	L	Aralık	
SK30-HC20-085	SK30	20	50	85	3-20	
SK30-HC20-100				100		
SK40-HC20-085	SK40	20	50	85	3-20	
SK40-HC20-135				135		
SK40-HC25-100				100		3-25
SK40-HC32-105	SK40	32	70	105	3-32	
SK40-HC32-135				135		
SK40-HC20-105	SK50	20	50	105	3-20	
SK40-HC20-150				150		
SK40-HC25-100				100		3-25
SK40-HC32-110				110		3-32
SK40-HC32-135				135		
SK40-HC32-110	42	99	110	3-42		

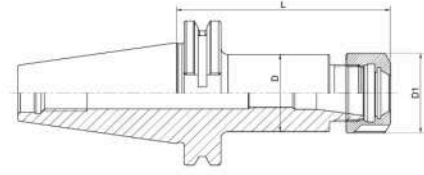

ÜrünKodu	Konik	D	D1	L	Kapasite
SK30-ER16UM-070	SK30	32	32	70	1-10
SK30-ER16UM-100		32	32	100	1-10
SK30-ER20UM-070		35	35	70	1-13
SK30-ER20UM-100		35	35	100	1-13
SK30-ER25-070		42	42	70	2-16
SK30-ER25-100		42	42	100	2-16
SK30-ER32-070		50	50	70	2-20
SK30-ER32-100		50	50	100	2-20
SK30-ER40-070		63	63	70	3-26
SK40-ER16UM-063		SK40	32	32	63
SK40-ER16UM-100	32		32	100	1-10
SK40-ER16UM-160	32		32	160	1-10
SK40-ER20UM-070	35		35	70	1-13
SK40-ER20UM-100	35		35	100	1-13
SK40-ER20UM-160	35		35	160	1-13
SK40-ER25-070	42		42	70	2-16
SK40-ER25-100	42		42	100	2-16
SK40-ER25-160	42		42	160	2-16
SK40-ER32-070	50		50	70	2-20
SK40-ER32-100	50		50	100	2-20
SK40-ER32-160	50		50	160	2-20
SK40-ER40-080	63		63	80	3-26
SK40-ER40-100	63		63	100	3-26
SK40-ER40-160	63		63	160	3-26
SK50-ER16UM-070	SK50		32	32	70
SK50-ER16UM-100		32	32	100	1-10
SK50-ER16UM-160		32	32	160	1-10
SK50-ER20UM-070		35	35	70	1-13
SK50-ER20UM-100		35	35	100	1-13
SK50-ER20UM-160		35	35	160	1-13
SK50-ER25-060		42	42	60	2-16
SK50-ER25-100		42	42	100	2-16
SK50-ER25-160		42	42	160	2-16
SK50-ER32-070		50	50	70	2-20
SK50-ER32-100		50	50	100	2-20
SK50-ER32-160		50	50	160	2-20
SK50-ER40-080		63	63	80	3-26
SK50-ER40-100		63	63	100	3-26
SK50-ER40-160		63	63	160	3-26

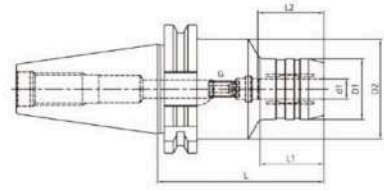

Ürün Kodu	Konik	d	D1	L1	L
SK30-HY06-070	SK30	6	26	20	70
SK30-HY08-070		8	28	20	70
SK30-HY10-075		10	30	21	75
SK30-HY12-085		12	32	40	85
SK30-HY14-085		14	34	42	85
SK30-HY16-090		16	38	50	90
SK30-HY18-090		18	40	50	90
SK30-HY20-090		20	42	50	90
SK40-HY06-080	SK40	6	26	30	80
SK40-HY08-080		8	28	30	80
SK40-HY10-080		10	30	31	80
SK40-HY12-080		12	32	31	80
SK40-HY14-080		14	34	33	80
SK40-HY16-080		16	38	34	80
SK40-HY18-080		18	40	55	80
SK40-HY20-080		20	42	55	80
SK40-HY25-080	25	55	58	80	
SK40-HY32-080	32	63	62	80	

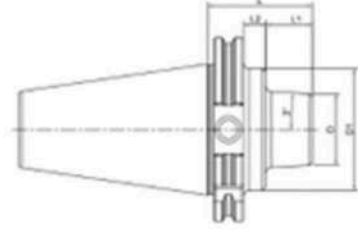

Ürün Kodu	Konik	D	L	L1	Aralık
SK30-TSF12-35	SK30	38	35	15.9	3-12
SK40-TSF12-45	SK40		45	25.9	3-12
SK40-TSF12-75			75	55.9	3-12
SK50-TSF12-75			75	43.9	3-12
SK50-TSF12-225	SK50		225	193.9	3-12
SK50-TSF12-315			315	243.9	3-12

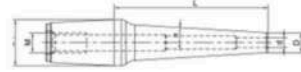

Ürün Kodu	d	D	L	$\alpha$	M
12-SF3-55S	3	6	55	3	M10
12-SF3-80S			80		
12-SF3-110S			110		
12-SF4-55S	4	7	55	3	M10
12-SF4-80S			80		
12-SF4-110S			110		
12-SF5-55S	5	8	55	3	M10
12-SF5-80S			80		
12-SF5-110S			110		
12-SF6-55S	6	9	55	3	M10
12-SF6-80S			80		
12-SF6-110S			110		
12-SF8-55S	8	11	55	3	M10
12-SF8-80S			80		
12-SF8-110S			110		
12-SF10-55S	10	13	55	3	M10
12-SF10-80S			80		
12-SF10-110S			110		
12-SF12-55S	12	15	55	3	M10
12-SF12-80S			80		
12-SF12-110S			110		

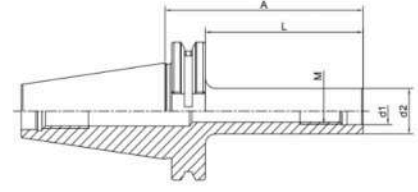

Ürün Kodu	Konik	D	D1	L	Aralık
SK40-M10-119	SK40	M10	18	100	119
SK40-M10-169				150	169
SK40-M12-119				100	119
SK40-M12-144		M12	21	125	144
SK40-M12-169				150	169
SK40-M16-119				100	119
SK40-M16-144		M16	29	125	144
SK40-M16-169				150	169
SK50-M10-119				SK50	M10
SK50-M10-169	150	169			
SK50-M12-119	100	119			
SK50-M12-169	M12	21	150		169
SK50-M16-119			100		119
SK50-M16-169			150		169



HSK-A

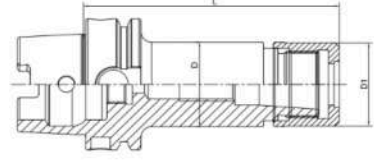

Ürün Kodu	Konik	D	D1	L	Aralık
HSK63A-SKS10-090	HSK63A	27.5	27.1	90	2-10
HSK63A-SKS10-150				150	
HSK63A-SKS16-090		40.6	40	90	3-16
HSK63A-SKS16-150				150	
HSK63A-SKS25-090				55.6	
HSK63A-SKS25-150		150			
HSK100A-SKS10-090	HSK100A	27.5	27.1	90	2-10
HSK100A-SKS10-150				150	
HSK100A-SKS16-090		40.6	40	90	3-16
HSK100A-SKS16-150				150	
HSK100A-SKS25-090				55.6	
HSK100A-SKS25-150		150			





ÜrünKodu	Konik	D	L	Kapasite
HSK63A-SDC06-060	HSK63A	14	60	3-6
HSK63A-SDC06-090			90	
HSK63A-SDC06-120			120	
HSK63A-SDC06-150			150	
HSK63A-SDC08-060		22	60	3-8
HSK63A-SDC08-090			90	
HSK63A-SDC08-120			120	
HSK63A-SDC08-150			150	
HSK63A-SDC08-200		34	200	3-12
HSK63A-SDC12-090			90	
HSK63A-SDC12-120			120	
HSK63A-SDC12-150			150	
HSK63A-SDC12-200	HSK100A	14	200	3-6
HSK100A-SDC06-110			110	
HSK100A-SDC06-150		22	150	3-8
HSK100A-SDC08-110			110	
HSK100A-SDC08-150			150	
HSK100A-SDC08-200		34	200	3-12
HSK100A-SDC12-120			120	
HSK100A-SDC12-150			150	
HSK100A-SDC12-200		200		

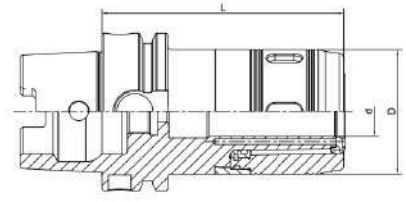

ÜrünKodu	Konik	d	D	L	Kapasite
HSK63A-HC20-100	HSK63A	20	50	100	3-20
HSK63A-HC25-100		25	59	100	3-25
HSK63A-HC32-120		32	70	120	3-32
HSK100A-HC20-105	HSK100A	20	50	105	3-20
HSK100A-HC25-105		25	59	105	3-25
HSK100A-HC32-120		32	70	120	3-32

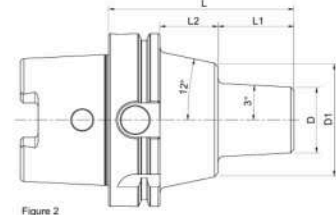
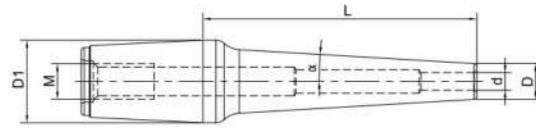
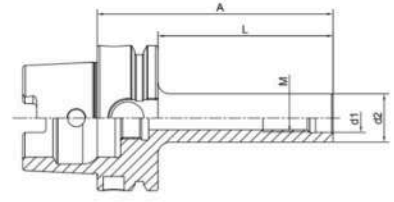

Figure 2

Ürün Kodu	Konik	D	L	L1	Aralık
HSK63A-TSF12-75K	HSK63A	41	75	49	3-12
HSK63A-TSF12-135K			135	109	3-12
HSK100A-TSF12-105K	HSK100A	41	105	43	3-12
HSK100A-TSF12-135K			135	73	3-12



Ürün Kodu	d	D	L	$\alpha$	M
12-SF3-55S	3	6	55	3	M10
12-SF3-80S			80		
12-SF3-110S			110		
12-SF4-55S	4	7	55	3	M10
12-SF4-80S			80		
12-SF4-110S			110		
12-SF5-55S	5	8	55	3	M10
12-SF5-80S			80		
12-SF5-110S			110		
12-SF6-55S	6	9	55	3	M10
12-SF6-80S			80		
12-SF6-110S			110		
12-SF8-55S	8	11	55	3	M10
12-SF8-80S			80		
12-SF8-110S			110		
12-SF10-55S	10	13	55	3	M10
12-SF10-80S			80		
12-SF10-110S			110		
12-SF12-55S	12	15	55	3	M10
12-SF12-80S			80		
12-SF12-110S			110		



Ürün Kodu	Konik	M	d2	A	L
HSK63A-M10-126	HSK63A	M10	18	126	100
HSK63A-M10-176				176	150
HSK63A-M12-101		M12	21	101	75
HSK63A-M12-126				126	100
HSK63A-M12-176				176	150
HSK63A-M16-101		M16	29	101	75
HSK63A-M16-126	126			100	
HSK63A-M16-176	176			150	
HSK100A-M10-129	HSK100A	M10	18	129	100
HSK100A-M10-179				179	150
HSK100A-M12-129		M12	21	129	100
HSK100A-M12-179				179	150
HSK100A-M16-129		M16	29	129	100
HSK100A-M16-179				179	150

# Hassas Bara

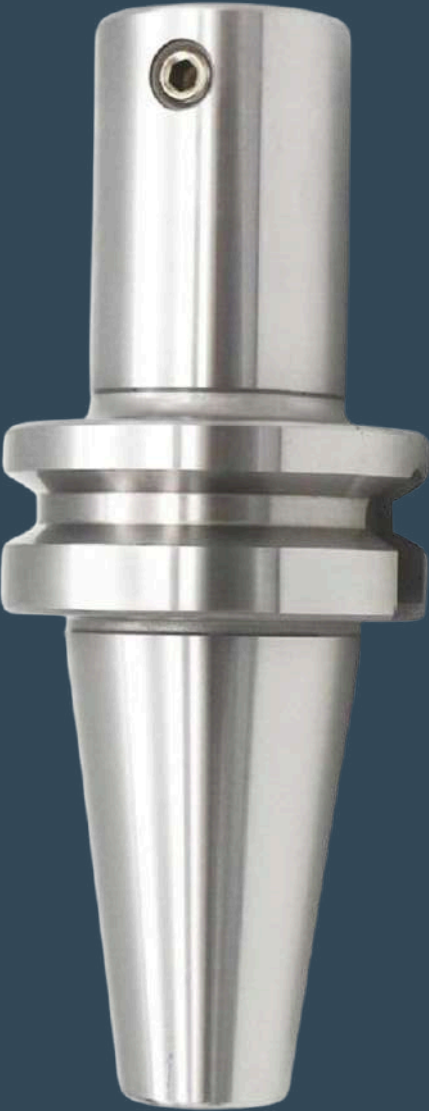



Ürün Kodu	Tutucu	Kartuş	Aralık İç	Aralık Dış	Uç
CBA20 (20-36)	LBK1	ENH1-1	20-26	-	TP08
		ENH1-2	25-31	30-31	
		ENH1-3	30-36	30-36	
CBA25 (25-47)	LBK2	ENH2-1	25-33	-	TP08
		ENH2-2	32-40	36-40	
		ENH2-3	39-47	39-47	
CBA32 (32-60)	LBK3	ENH3-1	32-42	-	TP08
		ENH3-2	41-51	46-51	
		ENH3-3	50-60	50-60	
CBA40 (40-79)	LBK4	ENH4-1	40-55	-	TC11
		ENH4-2	51-66	53-63	
		ENH4-3	64-79	64-79	
CBA52 (52-112)	LBK5	ENH5-1	52-75	62-70	TC11
		ENH5-2	70-93	65-82	
		ENH5-3	89-112	78-95	
CBA68 (68-150)	LBK6	ENH6-1	68-100	80-100	TP08
		ENH6-2	94-125	94-126	
		ENH6-3	118-150	118-150	
CBA100 (100-203)	LBK6	ENH6-1	100-153	112-153	TP08
		ENH6-2	126-179	126-179	
		ENH6-3	150-203	150-203	
CBA150 (150-210)	LBK6/BST		150-210	150-203	TC11

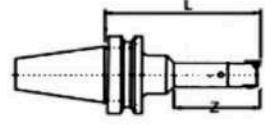

Fig1

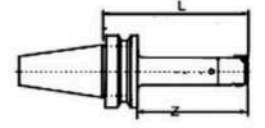
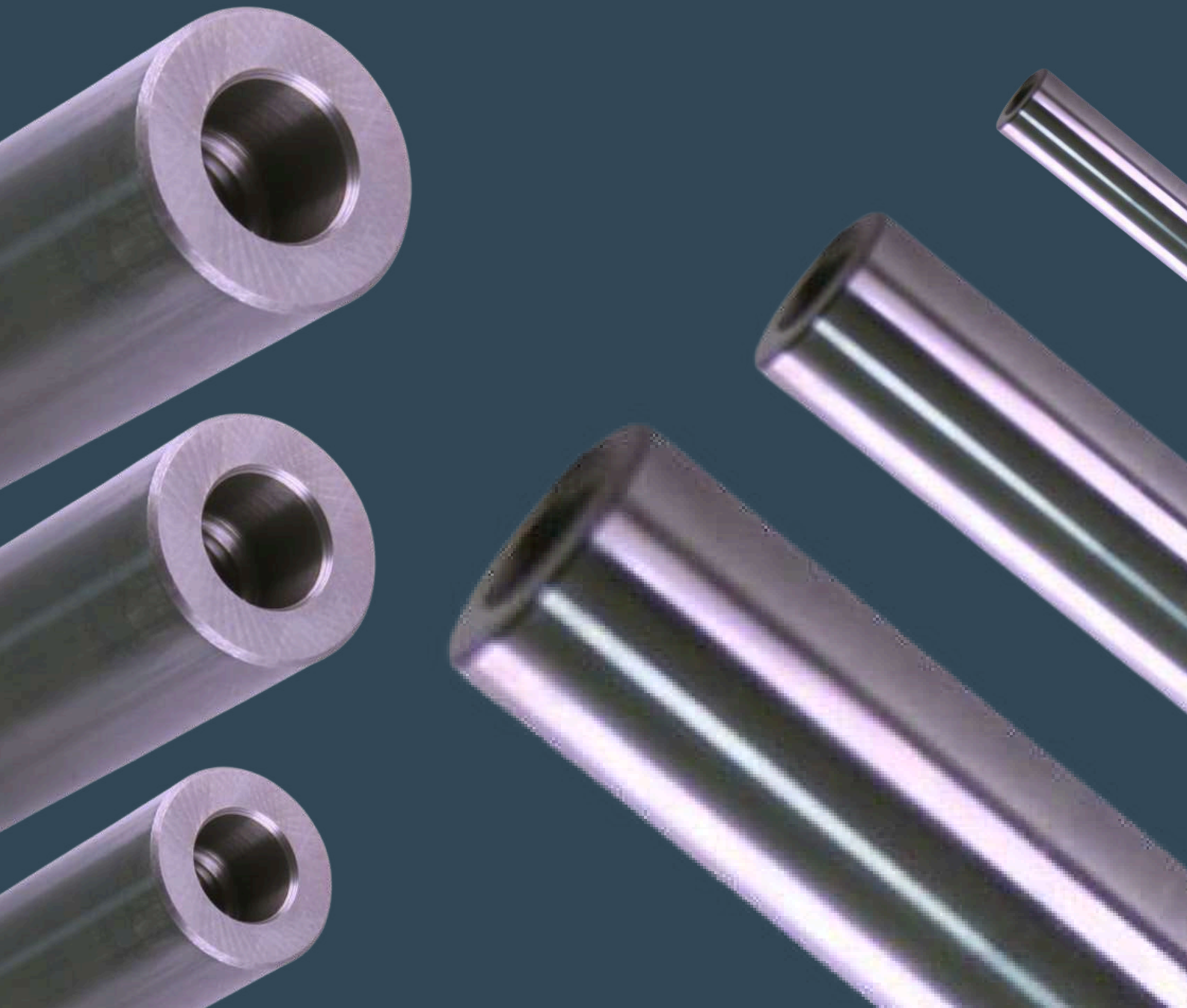

Fig2

Ürün Kodu	CBA	Z	Aralık	Fig	L
BT30-LBK1-070	CBA20	75	20-26-36	2	105
BT30-LBK2-080	CBA25	90	25-33-47		120
BT30-LBK3-080	CBA32		32-42-60		
BT30-LBK4-070	CBA40		40-55-79		
BT30-LBK5-060	CBA52		52-75-112		
BT30-LBK6-060	CBA68	100	68-102-150		
BT40-LBK1-075	CBA20	75	20-26-36	2	
BT40-LBK1-105		105			140
BT40-LBK2-085	CBA25	90	25-33-47		125
BT40-LBK2-115		120			155
BT40-LBK3-095	CBA32	100	32-42-60		135
BT40-LBK3-125		130			165
BT40-LBK3-155		160			195
BT40-LBK4-085	CBA40	100	40-55-79		135
BT40-LBK4-130		145			180
BT40-LBK4-175		190			225
BT40-LBK5-075	CBA52	100	52-75-112		135
BT40-LBK5-125		150			185
BT40-LBK5-175		200		235	
BT40-LBK6-065	CBA68	100	68-102-150	135	
BT40-LBK6-115		150		185	
BT40-LBK6-165		200		235	
BT40-LBK6-065	CBA100	100	100-152-203	135	
BT40-LBK6-115		150		185	
BT40-LBK6-165		200		235	
BT40-LBK6-065	CBA150	100	150-202	135	
BT40-LBK6-115		150		185	
BT40-LBK6-165		200		235	
BT50-LBK1-115	CBA20	75	20-26-36	1	150
BT50-LBK1-145		105			180
BT50-LBK2-110	CBA25	105	25-33-47		150
BT50-LBK2-140		135			180
BT50-LBK3-125	CBA32	120	32-42-60		165
BT50-LBK3-155		150			195
BT50-LBK4-115	CBA40	120	40-55-79		165
BT50-LBK4-145		150			195
BT50-LBK4-175		180			225
BT50-LBK4-205		210			255
BT50-LBK5-105	CBA52	120	52-75-112		165
BT50-LBK5-180		195			240
BT50-LBK5-240		255		300	
BT50-LBK5-300		315		360	
BT50-LBK6-095	CBA68	120	68-102-150	165	
BT50-LBK6-170		195		240	
BT50-LBK6-230		255		300	
BT50-LBK6-290		315		360	
BT50-LBK6-350		375		420	



# Karbür Gövde



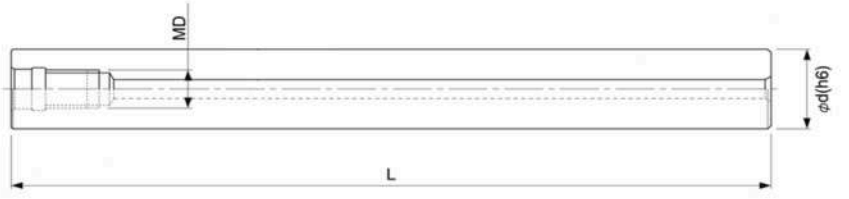

Ürün Kodu	d	MD	L
MSN-M5-100S-S10C	10	M5	100
MSN-M5-150S-S10C			150
MSN-M6-100S-S10C	10	M6	100
MSN-M6-150S-S10C			150
MSN-M6-100S-S12C	12	M6	100
MSN-M6-150S-S12C			150
MSN-M6-200S-S12C			200
MSN-M8-100S-S16C	16	M8	100
MSN-M8-150S-S16C			150
MSN-M8-200S-S16C			200
MSN-M8-250S-S16C			250
MSN-M8-300S-S16C			300
MSN-M10-150S-S18C	18	M10	150
MSN-M10-200S-S18C			200
MSN-M10-250S-S18C			250
MSN-M10-100S-S20C	20	M10	100
MSN-M10-150S-S20C			150
MSN-M10-200S-S20C			200
MSN-M10-250S-S20C			250
MSN-M10-300S-S20C			300
MSN-M12-150S-S24C	24	M12	150
MSN-M12-200S-S24C			200
MSN-M12-250S-S24C			250
MSN-M12-300S-S24C			300
MSN-M12-150S-S25C	25	M12	150
MSN-M12-200S-S25C			200
MSN-M12-250S-S25C			250
MSN-M12-300S-S25C			300
MSN-M12-350S-S25C			350
MSN-M16-200S-S28C	28	M16	200
MSN-M16-250S-S28C			250
MSN-M16-300S-S28C			300
MSN-M16-200S-S32C	32	M16	200
MSN-M16-250S-S32C			250
MSN-M16-300S-S32C			300
MSN-M16-350S-S32C			350
MSN-M16-400S-S32C			400

# Tarama Kafası

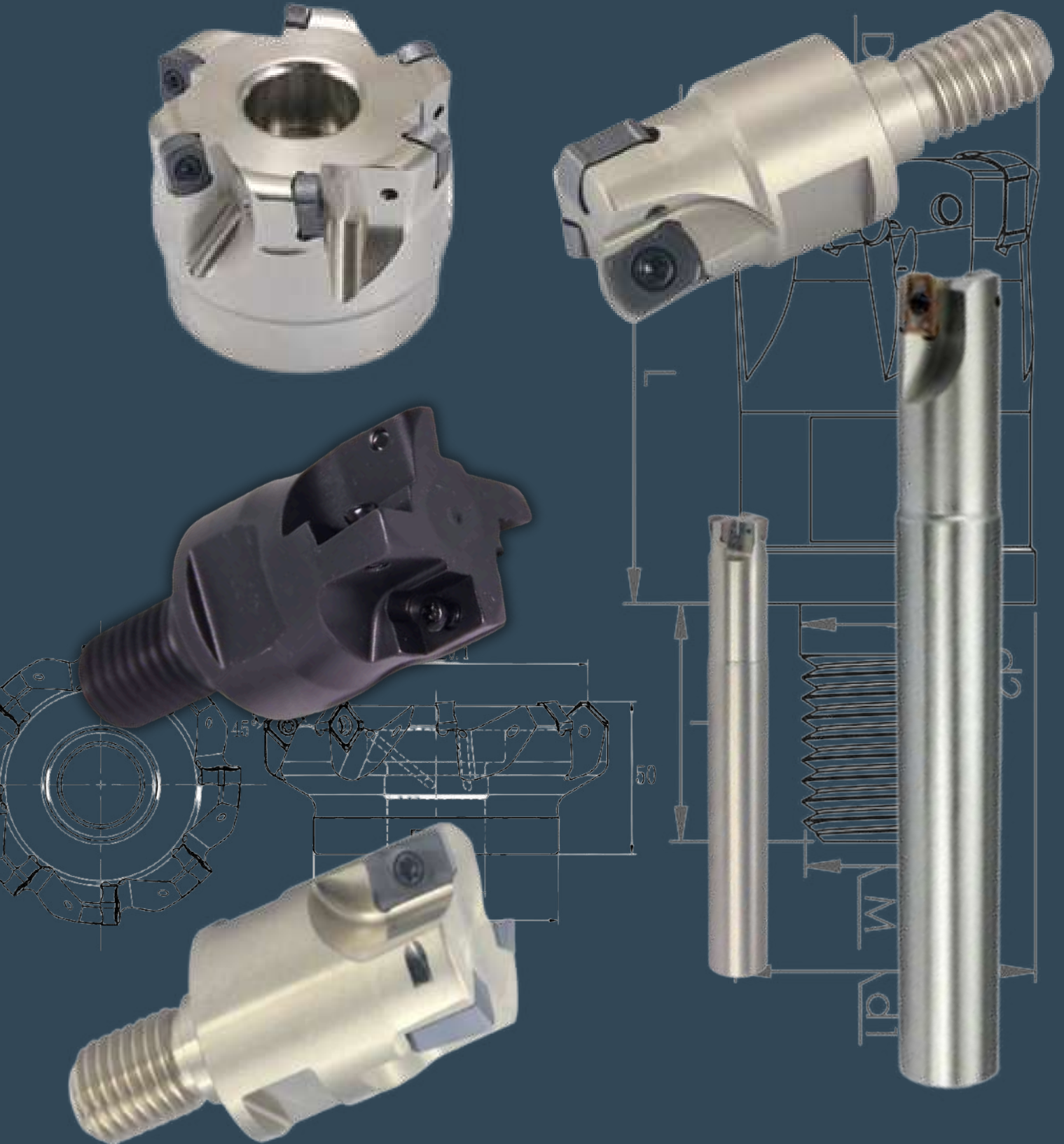

## APMT11



ÜrünKodu	D	d	L	Z	TIP
ST-APMT11-10-120	10	10	120	1	SAPLI
ST-APMT11-11-120	11	10	120	1	SAPLI
ST-APMT11-12-120	12	12	130	1	SAPLI
ST-APMT11-13-120	13	12	130	1	SAPLI
ST-APMT11-16-150	16	16	150	2	SAPLI
ST-APMT11-16-200	16	16	200	2	SAPLI
ST-APMT11-16-250	16	16	250	2	SAPLI
ST-APMT11-16-300	16	16	300	2	SAPLI
ST-APMT11-16-350	16	16	350	2	SAPLI
ST-APMT11-17-150	17	16	150	2	SAPLI
ST-APMT11-17-200	17	16	200	2	SAPLI
ST-APMT11-17-250	17	16	250	2	SAPLI
ST-APMT11-17-300	17	16	300	2	SAPLI
ST-APMT11-17-350	17	16	350	2	SAPLI
ST-APMT11-20-150	20	20	150	2	SAPLI
ST-APMT11-20-200	20	20	200	2	SAPLI
ST-APMT11-20-250	20	20	250	2	SAPLI
ST-APMT11-20-300	20	20	300	2	SAPLI
ST-APMT11-20-350	20	20	350	2	SAPLI
ST-APMT11-21-150	21	20	150	2	SAPLI
ST-APMT11-21-200	21	20	200	2	SAPLI
ST-APMT11-21-250	21	20	250	2	SAPLI
ST-APMT11-21-300	21	20	300	2	SAPLI
ST-APMT11-21-350	21	20	350	2	SAPLI
ST-APMT11-25-150	25	25	150	3	SAPLI
ST-APMT11-25-200	25	25	200	3	SAPLI
ST-APMT11-25-250	25	25	250	3	SAPLI
ST-APMT11-25-300	25	25	300	3	SAPLI
ST-APMT11-25-350	25	25	350	3	SAPLI
ST-APMT11-25-400	25	25	400	3	SAPLI
ST-APMT11-26-150	26	25	150	3	SAPLI
ST-APMT11-26-200	26	25	200	3	SAPLI
ST-APMT11-26-250	26	25	250	3	SAPLI
ST-APMT11-26-300	26	25	300	3	SAPLI
ST-APMT11-26-350	26	25	350	3	SAPLI
ST-APMT11-26-400	26	25	400	3	SAPLI
ST-APMT11-33-200	33	32	200	3	SAPLI
ST-APMT11-33-250	33	32	250	3	SAPLI
ST-APMT11-33-300	33	32	300	3	SAPLI
ST-APMT11-33-350	33	32	350	3	SAPLI
ST-APMT11-33-400	33	32	400	3	SAPLI
VT-APMT11-16-M08	16	-	M08	2	VİDALI
VT-APMT11-17-M08	17	-	M08	2	VİDALI
VT-APMT11-20-M10	20	-	M10	2	VİDALI
VT-APMT11-21-M10	21	-	M10	2	VİDALI
VT-APMT11-25-M12	25	-	M12	3	VİDALI
VT-APMT11-26-M12	26	-	M12	3	VİDALI
VT-APMT11-32-M16	32	-	M16	3	VİDALI
VT-APMT11-35-M16	35	-	M16	3	VİDALI

genco  
makina

## BLMP06



ÜrünKodu	D	d	L	Z	TIP
ST-BLMP06-16-150	16	16	150	2	SAPLI
ST-BLMP06-16-200	16	16	200	2	SAPLI
ST-BLMP06-17-150	17	16	150	2	SAPLI
ST-BLMP06-17-200	17	16	200	2	SAPLI
ST-BLMP06-20-150	20	20	150	3	SAPLI
ST-BLMP06-20-200	20	20	200	3	SAPLI
ST-BLMP06-21-150	21	20	150	3	SAPLI
ST-BLMP06-21-200	21	20	200	3	SAPLI
ST-BLMP06-25-150	25	25	150	4	SAPLI
ST-BLMP06-25-200	25	25	200	4	SAPLI
ST-BLMP06-26-150	26	25	150	4	SAPLI
ST-BLMP06-26-200	26	25	200	4	SAPLI
ST-BLMP06-32-150	26	25	150	5	SAPLI
ST-BLMP06-32-200	26	25	200	5	SAPLI
ST-BLMP06-33-150	26	25	150	5	SAPLI
ST-BLMP06-33-200	26	25	200	5	SAPLI
VT-BLMP06-25-M12	25	M12	-	4	VIDALI
VT-BLMP06-32-M16	32	M16	-	5	VIDALI
VT-BLMP06-35-M16	35	M16	-	5	VIDALI
VT-BLMP06-40-M16	40	M16	-	6	VIDALI
VT-BLMP06-42-M16	42	M16	-	6	VIDALI
AT-BLMP06-40-016	40	16	-	6	TARAMA
AT-BLMP06-50-022	50	22	-	7	TARAMA
AT-BLMP06-63-022	63	22	-	8	TARAMA

genco  
makina

BLMP09



ÜrünKodu	D	d	L	Z	TIP
VT-BLMP09-25-M12	25	M12	-	3	VİDALI
VT-BLMP09-32-M16	32	M16	-	4	VİDALI
VT-BLMP09-35-M16	35	M16	-	4	VİDALI
VT-BLMP09-40-M16	40	M16	-	5	VİDALI
AT-BLMP09-40-016	40	16	-	5	TARAMA
AT-BLMP09-50-022	50	22	-	6	TARAMA
AT-BLMP09-63-022	63	22	-	7	TARAMA
AT-BLMP09-66-027	63	27	-	8	TARAMA

genco  
makina

## JDMT07



ÜrünKodu	D	d	L	Z	TIP
ST-JDMT07-10-120	10	10	120	2	SAPLI
ST-JDMT07-11-120	11	10	120	2	SAPLI
ST-JDMT07-12-130	12	12	130	2	SAPLI
ST-JDMT07-13-130	13	12	130	2	SAPLI
ST-JDMT07-14-150	14	14	150	3	SAPLI
ST-JDMT07-15-150	15	14	150	3	SAPLI
ST-JDMT07-16-150	16	16	150	3	SAPLI
ST-JDMT07-17-150	17	16	150	3	SAPLI
VT-JDMT07-10-M5	10	-	M5	2	VİDALI
VT-JDMT07-10-M6	10	-	M6	2	VİDALI
VT-JDMT07-11-M5	11	-	M5	2	VİDALI
VT-JDMT07-11-M6	11	-	M6	2	VİDALI
VT-JDMT07-12-M6	12	-	M6	2	VİDALI
VT-JDMT07-13-M6	13	-	M6	2	VİDALI
VT-JDMT07-14-M6	14	-	M6	3	VİDALI
VT-JDMT07-16-M8	16	-	M8	3	VİDALI
VT-JDMT07-17-M8	17	-	M8	3	VİDALI

genco  
makina

LPGT



ÜrünKodu	D	d	L	Z	TIP
ST-LPGT01-08-080	8	10	80	1	SAPLI
ST-LPGT01-09-080	9	10	80	1	SAPLI
ST-LPGT01-10-080	10	10	80	2	SAPLI
ST-LPGT01-11-080	11	10	80	2	SAPLI
ST-LPGT01-12-080	12	12	80	3	SAPLI
ST-LPGT01-13-080	13	12	80	3	SAPLI
ST-LPGT01-14-120	14	14	120	3	SAPLI
ST-LPGT01-15-120	15	16	120	4	SAPLI
ST-LPGT01-16-120	16	16	120	4	SAPLI
VT-LPGT01-10-M5	10	-	M5	2	VİDALI
VT-LPGT01-11-M5	11	-	M5	2	VİDALI
VT-LPGT01-12-M6	12	-	M6	3	VİDALI
VT-LPGT01-13-M6	13	-	M6	3	VİDALI
VT-LPGT01-14-M6	14	-	M6	3	VİDALI
VT-LPGT01-15-M6	15	-	M6	4	VİDALI
VT-LPGT01-16-M8	16	-	M8	4	VİDALI
VT-LPGT01-17-M8	17	-	M8	4	VİDALI

genco  
makina

## MPHW06



ÜrünKodu	D	d	L	Z	TIP
VT-MPHW06-16-M08	16	-	M08	2	VIDALI
VT-MPHW06-17-M08	17	-	M08	2	VIDALI
VT-MPHW06-20-M10	20	-	M10	3	VIDALI
VT-MPHW06-21-M10	21	-	M10	3	VIDALI
VT-MPHW06-25-M12	25	-	M12	4	VIDALI
VT-MPHW06-26-M12	26	-	M12	4	VIDALI
VT-MPHW06-32-M16	32	-	M16	4	VIDALI
VT-MPHW06-35-M16	35	-	M16	4	VIDALI

# Hızlı Bağlama

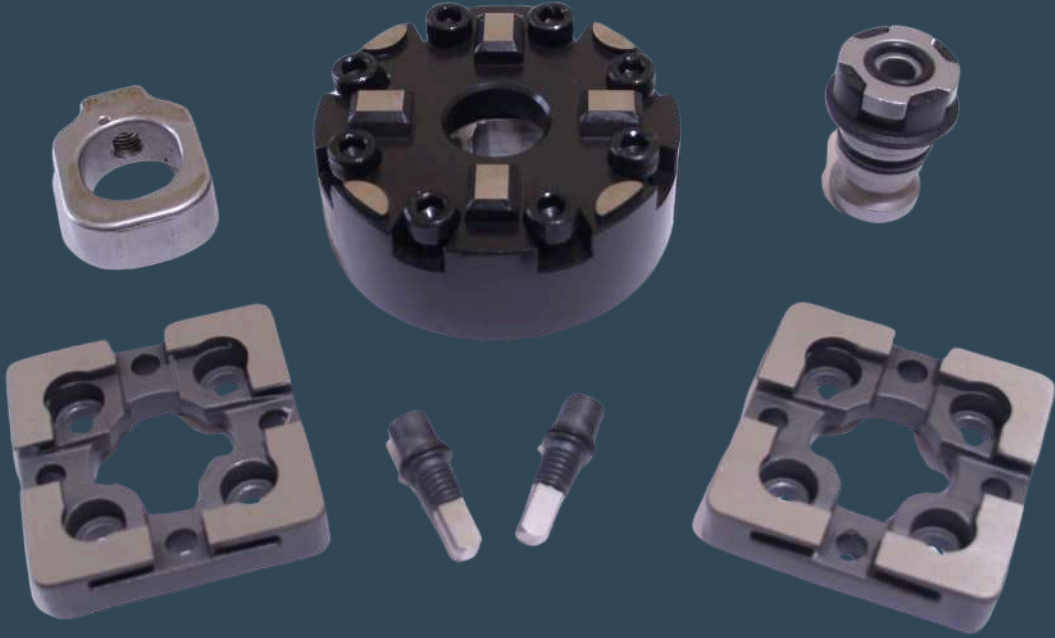



**Palet**



**Ayna**



**Çektirme**



**Yedek Parça**

The logo for Genco Makina features the word "genco" in a large, white, lowercase sans-serif font. Below it, the word "makina" is written in a smaller, blue, lowercase sans-serif font. The logo is centered within a white circular shape that is partially obscured by a dark blue horizontal band.

genco  
makina

Parmak Freze

Takma Uç

Kılavuz

Takım Tutucu

Hassas Bara

Karbür Gövde

Tarama Kafası

Hızlı Bağlama Sistemi

Çamlık Mahallesi, Yahya Kemal Beyatlı Caddesi, Yonca Sokak, No:7/1 Pendik İstanbul

info@gencomakina.com - +90 533 365 96 42

www.gencomakina.com.tr